



Franklin Electric

SUBMERSIBLE PUMPS FOR SEWAGE

FWS-FWC, FGR AND FLV SERIES



INDEX

FWS-FWC SERIES - WASTEWATER LIFT PUMPS 50 HZ

Pump identification code.....	6
32FWS V Series 50 HZ.....	7
Features & benefits.....	7
General features.....	8
Dimensional drawings.....	9
Technical data.....	10
Hydraulic performance at 50 Hz.....	10
Performance curves at 50 Hz.....	11
Installation.....	12
40FWS V Series 50 HZ.....	13
Features & benefits.....	13
General features.....	14
Dimensional drawings.....	15
Technical data.....	16
Hydraulic performance at 50 Hz.....	16
Performance curves at 50 Hz.....	17
Installation.....	18
50FWS V Series 50 HZ.....	19
Features & benefits.....	19
General features.....	20
Dimensional drawings.....	21
Technical data.....	22
Hydraulic performance at 50 Hz.....	22
Hydraulic performance at 50 Hz.....	23
Installation.....	24
50FWC V Series 50 HZ.....	25
Features & benefits.....	25
General features.....	26
Dimensional drawings.....	27
Technical data.....	28
Hydraulic performance at 50 Hz.....	28
Hydraulic performance at 50 Hz.....	29
Installation.....	30
50FWC M Series 50 HZ.....	31
Features & benefits.....	31
General features.....	32
Dimensional drawings.....	33
Technical data.....	34
Hydraulic performance at 50 Hz.....	34
Hydraulic performance at 50 Hz.....	35
Installation.....	36
50FWC V4 Series 50 HZ.....	37
Features & benefits.....	37
General features.....	38
Dimensional drawings.....	39
Technical data.....	40
Hydraulic performance at 50 Hz.....	40
Hydraulic performance at 50 Hz.....	41
Installation.....	42

NOTE: Franklin Electric reserves the right to amend specification without prior notice.

For the most up-to-date product information, visit franklinwater.eu.

65FWC V Series 50 HZ	43
Features & benefits	43
General features	44
Dimensional drawings	45
Technical data	46
Hydraulic performance at 50 Hz	46
Hydraulic performance at 50 Hz	47
65FWC M Series 50 HZ	49
Features & benefits	49
General features	50
Dimensional drawings	51
Technical data	52
Hydraulic performance at 50 Hz	52
Hydraulic performance at 50 Hz	53
Installation	54
65FWC V4 Series 50 HZ	55
Features & benefits	55
General features	56
Dimensional drawings	57
Technical data	58
Hydraulic performance at 50 Hz	58
Hydraulic performance at 50 Hz	59
Installation	60
80FWC M4 Series 50 HZ	61
Features & benefits	61
General features	62
Dimensional drawings	63
Technical data	64
Hydraulic performance at 50 Hz	64
Hydraulic performance at 50 Hz	65
80FWC V4 Series 50 HZ	67
Features & benefits	67
General features	68
Dimensional drawings	69
Technical data	70
Hydraulic performance at 50 Hz	70
Hydraulic performance at 50 Hz	71
100FWC M4 Series 50 HZ	73
Features & benefits	73
General features	74
Dimensional drawings	75
Technical data	76
Hydraulic performance at 50 Hz	76
Hydraulic performance at 50 Hz	77
Installation	78

NOTE: Franklin Electric reserves the right to amend specification without prior notice.

For the most up-to-date product information, visit franklinwater.eu.



FGR SERIES - PUMPS WITH GRINDER UNIT 50 HZ

Pump identification code.....80

40 FGR Series 50 HZ81

Features & benefits.....81

General features.....82

Dimensional drawings.....83

Technical data.....84

Hydraulic performance at 50 Hz.....84

Performance curves at 50 Hz.....85

Installation.....86

50FGR Series 50 HZ87

Features & benefits.....87

General features.....88

Dimensional drawings.....89

Technical data.....90

Hydraulic performance at 50 Hz.....90

Performance curves at 50 Hz.....91

Installation.....92

FLV SERIES - D.C. MOTOR SUBMERSIBLE WASTE WATER LIFT PUMPS 50 HZ

Pump identification code.....94

40FLV Series 50 HZ95

Features & benefits.....95

General features.....96

Dimensional drawings.....97

Technical data.....98

Hydraulic performance at 50 Hz.....98

Performance curves at 50 Hz.....99

Installation.....100

NOTE: Franklin Electric reserves the right to amend specification without prior notice.

For the most up-to-date product information, visit franklinwater.eu.

FWS-FWC Series - Wastewater lift pumps 50 Hz



FWS-FWC SERIES - WASTEWATER LIFT PUMPS 50 HZ

PUMP IDENTIFICATION CODE

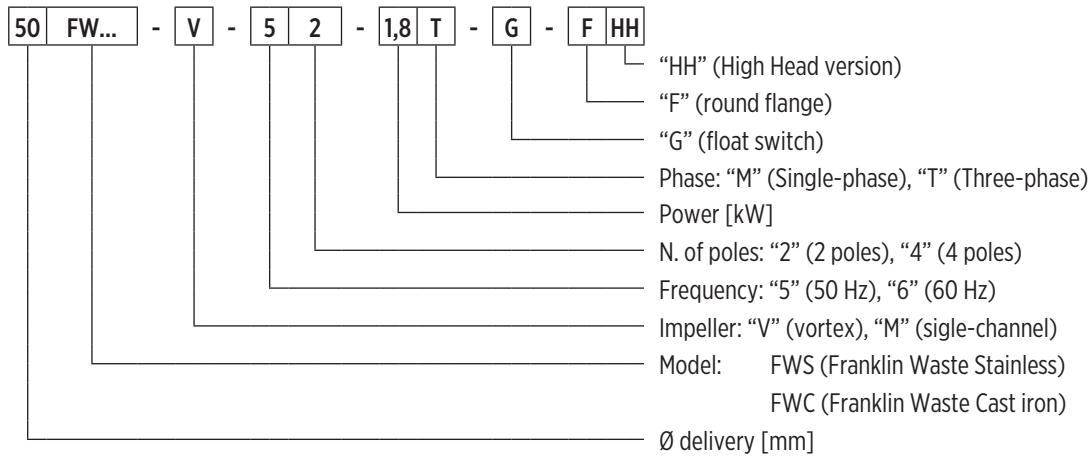

0014006 11/2022

32FWS V SERIES 50 HZ

FEATURES & BENEFITS

APPLICATIONS



Pumping of clear non-loaded fluids



Extraction of water from ponds, streams or pits and for rainwater collection



Wastewater



MARKETS



STAINLESS STEEL AND CAST IRON SUBMERSIBLE WASTEWATER LIFT PUMPS

Submersible electric pump particularly suitable for the emptying of basements, garages, cellars and flooded premises.

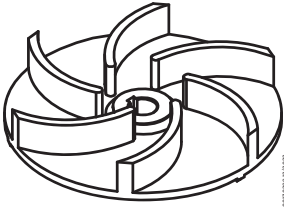

VORTEX IMPELLER

GENERAL FEATURES

		Materials/Constr.design
Vortex impeller		Cast iron EN GJL200
External casing		Stainless steel AISI304
Pump body		Cast iron EN GJL200
Cover		Cast iron EN GJL200
Mechanical seal	motor side	Seal ring
	pump side	Graphite/Alumina
Motor shaft		Stainless steel AISI416
Power cable		10 m H07RN-F type, 3G1 mm ² and SCHUKO plug
Motor		
Constr.design		asynchronous squirrel cage-type oil filled
Type		2 poles; 50 Hz
Insulation class		F
Protection degree		IP68
Voltage	Single-phase	230V ±6% built-in overheating protection, built in capacitor, float switch as optional
Limits of use		
Maximum liquid temperature		+40 °C
pH of pumped liquid		6 - 10
Liquid density		1,0 kg/dm ³
Maximum immersion depth:		5 m
Min. immersion depth for continuous service		250 mm
Free passage		30 mm
Max. number of starting/hour		20
Construction options		

- 60 Hz version
- Different voltages
- Food-grade white oil

DIMENSIONAL DRAWINGS

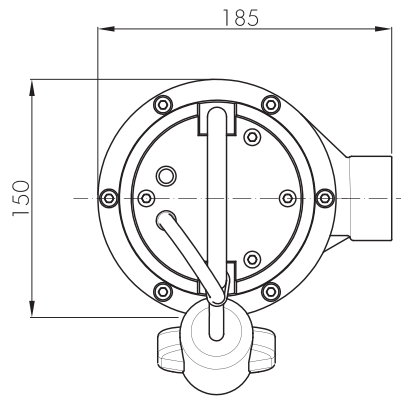
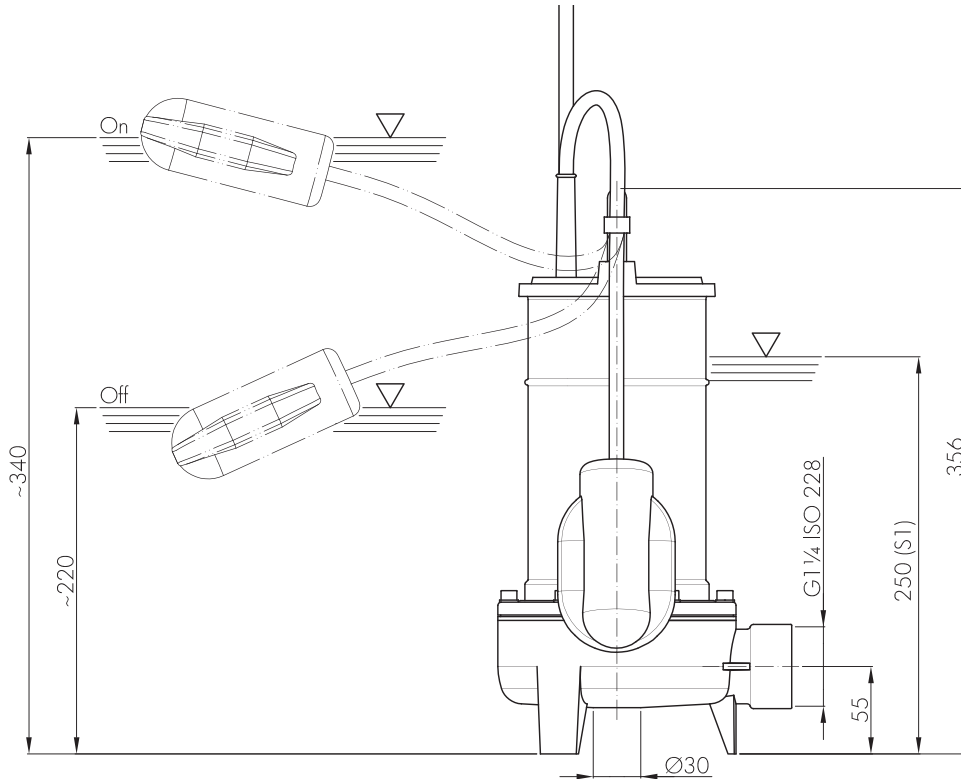

00130288 12/2022

Packaging		
Pump model	Dimensions [mm]	Weight [kg]
32 FWS V	225x180x450	11,5

Pallet		
Dimensions [mm]	N° of pumps	Weight [kg]
1200x800x800	32	400

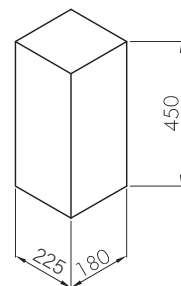
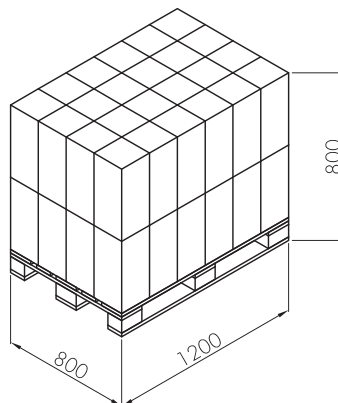

00130288 02/2023

TECHNICAL DATA

Pump model	Motor absorbed power P ₁	Rated power P ₂		Voltage	Rated current	Phase	Power cable		float switch	Running capacitor	Delivery port	Weight [kg]
	[kW]	[kW]	[HP]	[V]	[A]		length [m]	Type		[μf]		
32FWS-V-52-0,3M	0,57	0,3	0,4	230	2,8	1~	10	3G1	-	8	G1¼	11
32FWS-V-52-0,3M-G	0,57	0,3	0,4	230	2,8	1~	10	3G1	•	8	G1¼	11

"-" = not available • = available

HYDRAULIC PERFORMANCE AT 50 HZ

Pump model	Phase	Q = Delivery							
		l/sec 0	0,5	1	1,5	2	2,5	3	3,5
		m ³ /h 0	1,8	3,6	5,4	7,2	9	10,8	12,6
		US gpm 0	7,9	15,8	23,7	31,7	39,6	47,5	55,5
		H = Total meters head of water column [m]							
32FWS-V-52-0,3	1~	7,6	6,9	6,3	5,5	4,6	3,5	2,5	1,2

PERFORMANCE CURVES AT 50 HZ

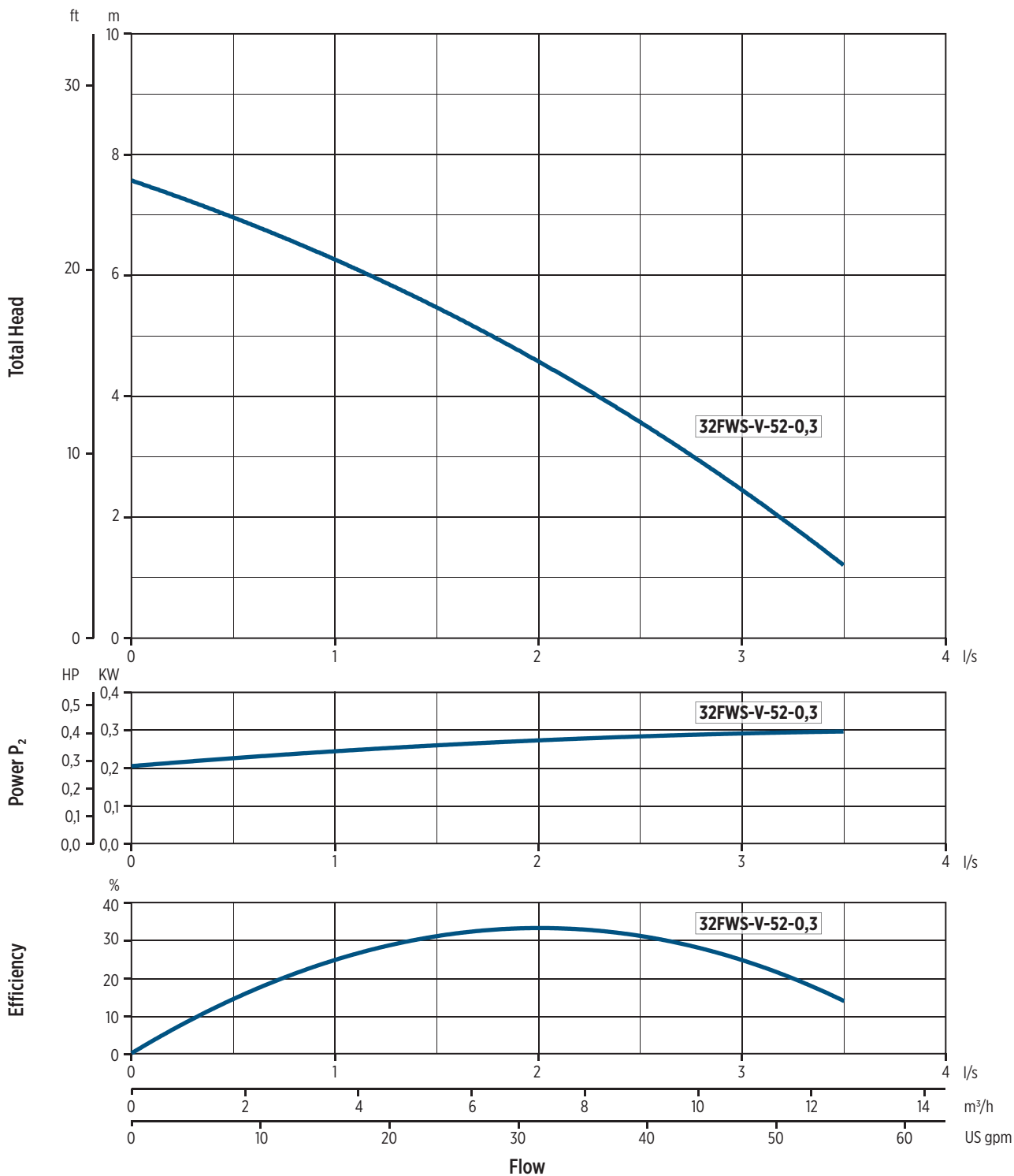

0020092 12/2022



INSTALLATION

INSTALLATION INSTRUCTIONS

TRANSPORTABLE INSTALLATION

Transportable as emergency pump with connection to the hose and for free installation in the well.

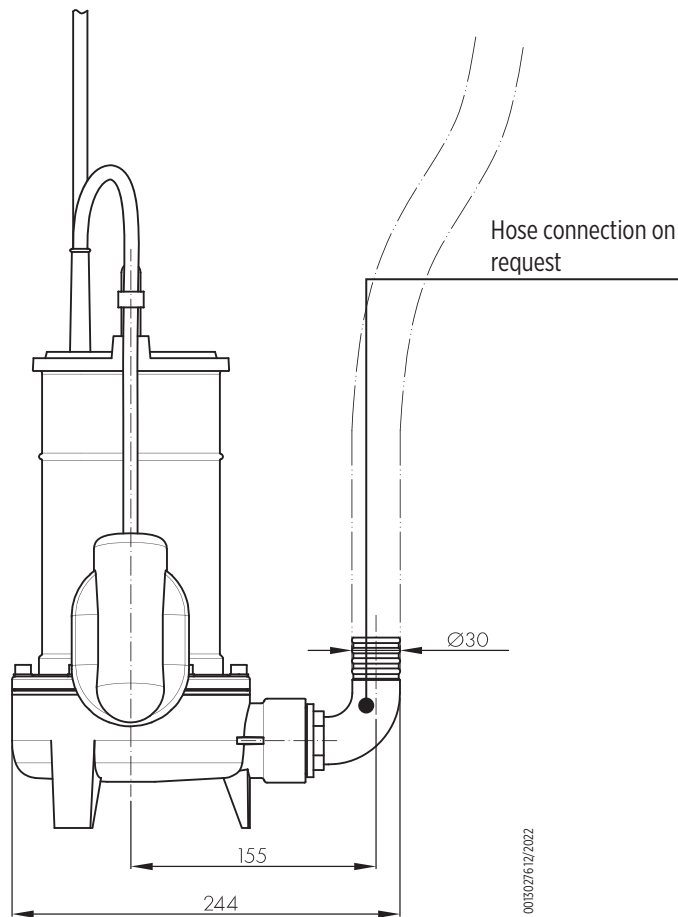

40FWS V SERIES 50 HZ

FEATURES & BENEFITS

APPLICATIONS



Pumping of clear non-loaded fluids



Extraction of water from ponds, streams or pits and for rainwater collection



Wastewater



MARKETS



STAINLESS STEEL AND CAST IRON SUBMERSIBLE WASTEWATER LIFT PUMPS

Submersible electric pump particularly suitable for the emptying of basements, garages, cellars and flooded premises.

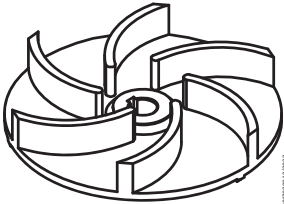

VORTEX IMPELLER

GENERAL FEATURES

		Materials/Constr.design
Vortex impeller		Cast iron EN GJL200
External casing		Stainless steel AISI304
Pump body		Cast iron EN GJL200
Cover		Cast iron EN GJL200
Mechanical seal	motor side	Seal ring
	pump side	Graphite/Alumina
Motor shaft		Stainless steel AISI416
Power cable	Type	10 m H07RN-F type
	Single-phase	3G1mm ² with SCHUKO plug (CEE 7/VII)
	Three-phase	4G1 mm ²
		Motor
Constr.design		asynchronous squirrel cage-type oil filled
Type		2 poles; 50 Hz
Insulation class		F
Protection degree		IP68
Voltage	Single-phase	230 V ±6% built-in overheating protection, built in capacitor, float switch as optional
	Three-phase	230V ±10%, 400V ±10%
		Limits of use
Maximum liquid temperature		+40 °C
pH of pumped liquid		6 - 10
Liquid density		1,0 kg/dm ³
Maximum immersion depth:		5 m
Min. immersion depth for continuous service		280 mm
Free passage		20 mm
Max. number of starting/hour		20
		Construction options

- 60 Hz version
- Different voltages
- Food-grade white oil
- Silicon carbide (SiC/SiC) mechanical seal

DIMENSIONAL DRAWINGS

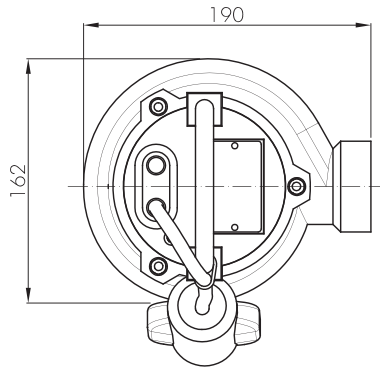
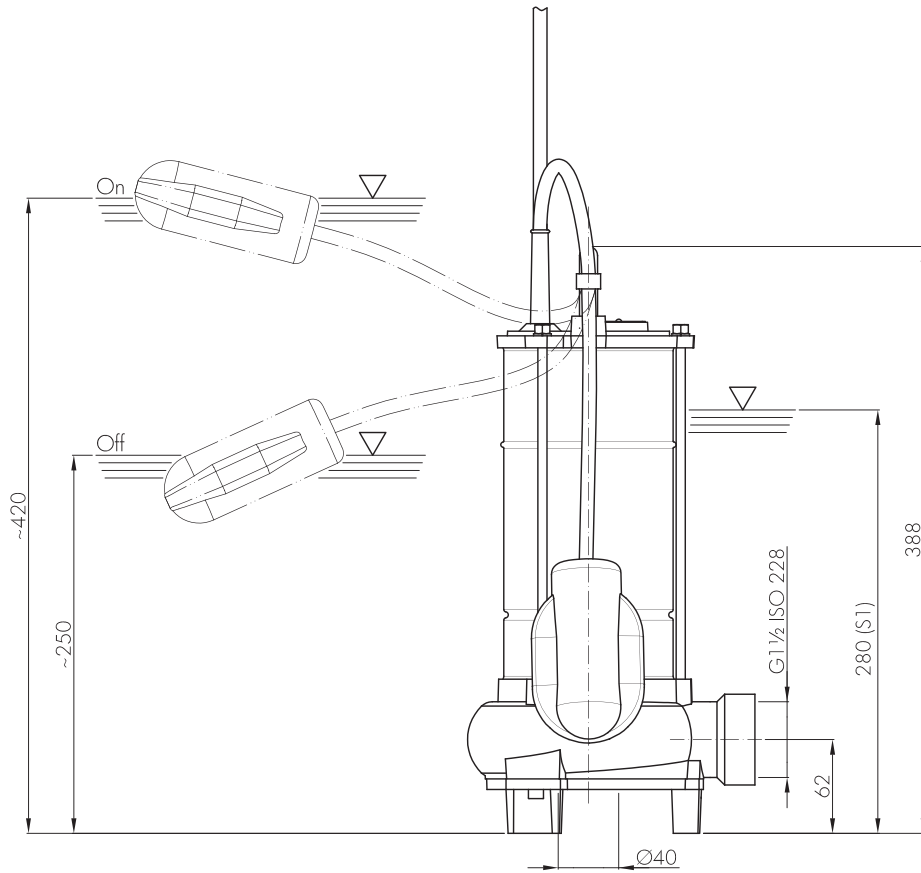

00502712/2022

Packaging		
Pump model	Dimensions [mm]	Weight [kg]
40 FWS V	225x180x450	13,5

Pallet		
Dimensions [mm]	N° of pumps	Weight [kg]
1200x800x800	32	460

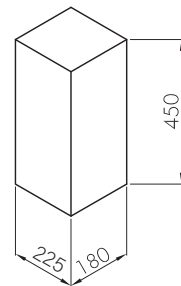
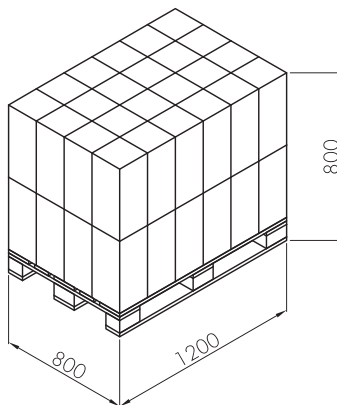

00130288 02/2023

TECHNICAL DATA

Pump model	Motor absorbed power P ₁	Rated power P ₂		Voltage [V]	Rated current [A]	Phase	Power cable		float switch	Running capacitor [μf]	Delivery port	Weight [kg]
	[kW]	[kW]	[HP]				length [m]	Type				
40FWS-V-52-0,37M	0,58	0,37	0,5	230	3	1 ~	10	3G1	-	8	G1½	13
40FWS-V-52-0,37M-G	0,58	0,37	0,5	230	3	1 ~	10	3G1	•	8	G1½	13
40FWS-V-52-0,6M	0,72	0,6	0,8	230	3,7	1 ~	10	3G1	-	10	G1½	13
40FWS-V-52-0,6M-G	0,72	0,6	0,8	230	3,7	1 ~	10	3G1	•	10	G1½	13
40FWS-V-52-0,7M	0,88	0,7	0,95	230	4,8	1 ~	10	3G1	-	14	G1½	14
40FWS-V-52-0,7M-G	0,88	0,7	0,95	230	4,8	1 ~	10	3G1	•	14	G1½	14
40FWS-V-52-0,7T	0,88	0,7	0,95	400	1,8	3 ~	10	4G1	-	-	G1½	14
40FWS-V-52-0,7T-G	0,88	0,7	0,95	400	1,8	3 ~	10	4G1	•	-	G1½	14

"-" = not available

• = available

HYDRAULIC PERFORMANCE AT 50 HZ

Pump model	Phase	Q = Delivery											
		l/sec 0	0,5	1	1,5	2	2,5	3	3,5	4	4,5	5	5,5
		m ³ /h 0	1,8	3,6	5,4	7,2	9	10,8	12,6	14,4	16,2	18	19,8
		US gpm 0	7,9	15,8	23,7	31,7	39,6	47,5	55,5	63,4	71,3	79,2	87,2
		H = Total meters head of water column [m]											
40FWS-V-52-0,37	1 ~	7	6,5	6	5,2	4,5	3,8	3	2,1				
40FWS-V-52-0,6	1 ~	8,1	7,8	7,1	6,8	6,2	5,7	5	4,1	3,3	2,3		
40FWS-V-52-0,7	1 ~	9,8	9	8,7	8,1	7,5	6,8	5,9	5	4,2	3,5	2,5	1,5
	3 ~	9,8	9	8,7	8,1	7,5	6,8	5,9	5	4,2	3,5	2,5	1,5

PERFORMANCE CURVES AT 50 HZ

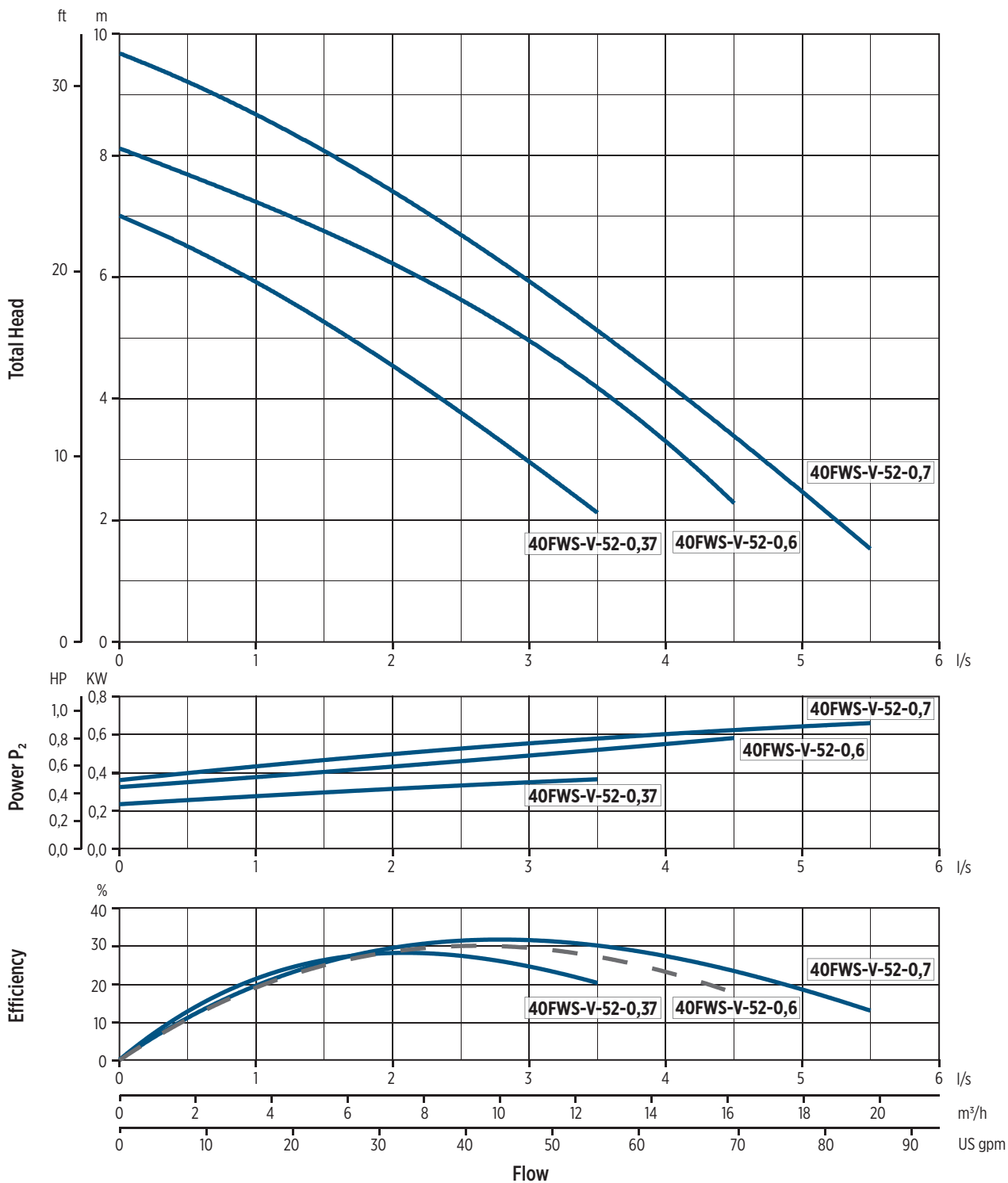

002009312/2022

INSTALLATION

INSTALLATION INSTRUCTIONS

PERMANENT INSTALLATION WITH COUPLING SYSTEM

It is the recommended installation for the permanent pumping station. The electric pump is guided by two pipes and it is connected automatically to the coupling system. The quick connection ensures that the pump can be easily removed and re-installed.

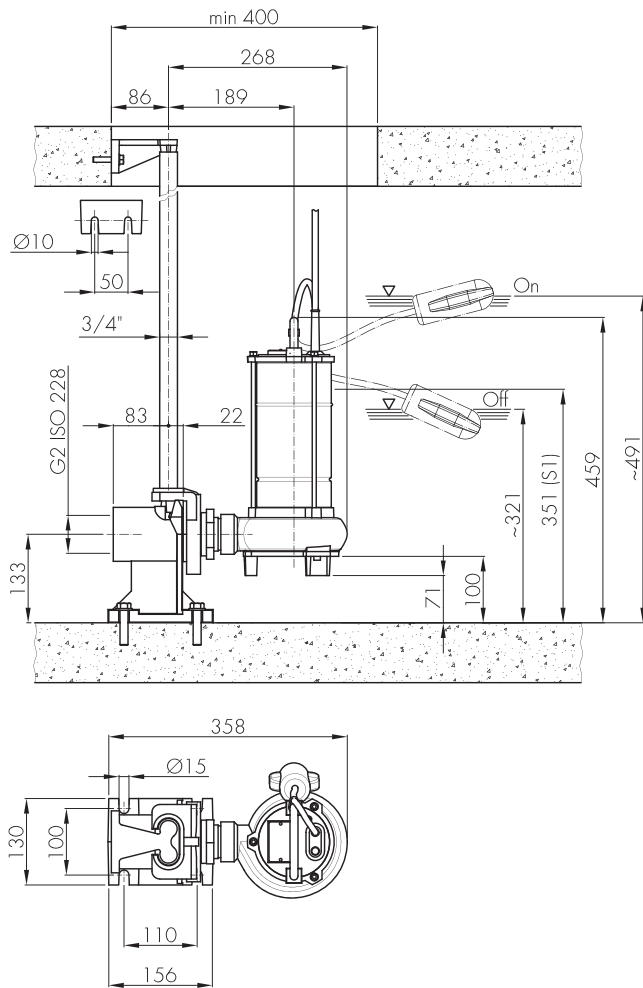

TRANSPORTABLE INSTALLATION

Transportable as emergency pump with connection to the hose and for free installation in the well.

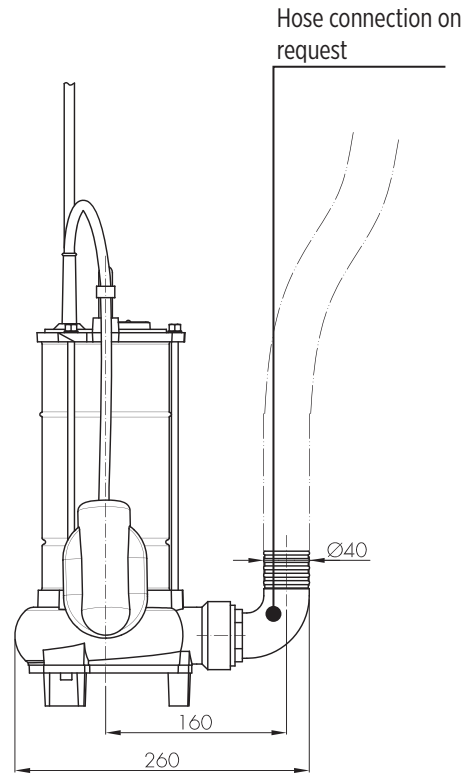

00130271/12/2022

50FWS V SERIES 50 HZ

FEATURES & BENEFITS

APPLICATIONS



Pumping of clear non-loaded fluids



Extraction of water from ponds, streams or pits and for rainwater collection



Wastewater



MARKETS



STAINLESS STEEL AND CAST IRON SUBMERSIBLE WASTEWATER LIFT PUMPS

Submersible electric pump particularly suitable for the emptying of basements, garages, cellars and flooded premises.

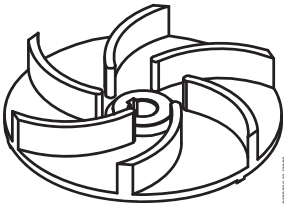

VORTEX IMPELLER

GENERAL FEATURES

		Materials/Constr.design
Vortex impeller		Cast iron EN GJL200
External casing		Stainless steel AISI304
Pump body		Cast iron EN GJL200
Cover		Cast iron EN GJL200
Mechanical seal	motor side	Seal ring
	pump side	Silicon carbide (SiC/SiC)
Motor shaft		Stainless steel AISI416
Power cable	Type	10 m H07RN-F type
	Single-phase	3G1 mm ² with SCHUKO plug (CEE 7/VII)
	Three-phase	4G1 mm ²
		Motor
Constr.design		asynchronous squirrel cage-type in dry chamber
Type		2 poles; 50 Hz
Insulation class		F
Protection degree		IP68
Voltage	Single-phase	230V ±6% built-in overheating protection, built in capacitor, float switch as optional
	Three-phase	230V ±10%, 400V ±10%
		Limits of use
Maximum liquid temperature		+40 °C
pH of pumped liquid		6 - 10
Liquid density		1,0 kg/dm ³
Maximum immersion depth:		5 m
Min. immersion depth for continuous service		375 mm
Free passage		50 mm
Max. number of starting/hour		20
		Construction options

- 60 Hz version
- Different voltages
- External capacitor with 4G1mm² cable

DIMENSIONAL DRAWINGS

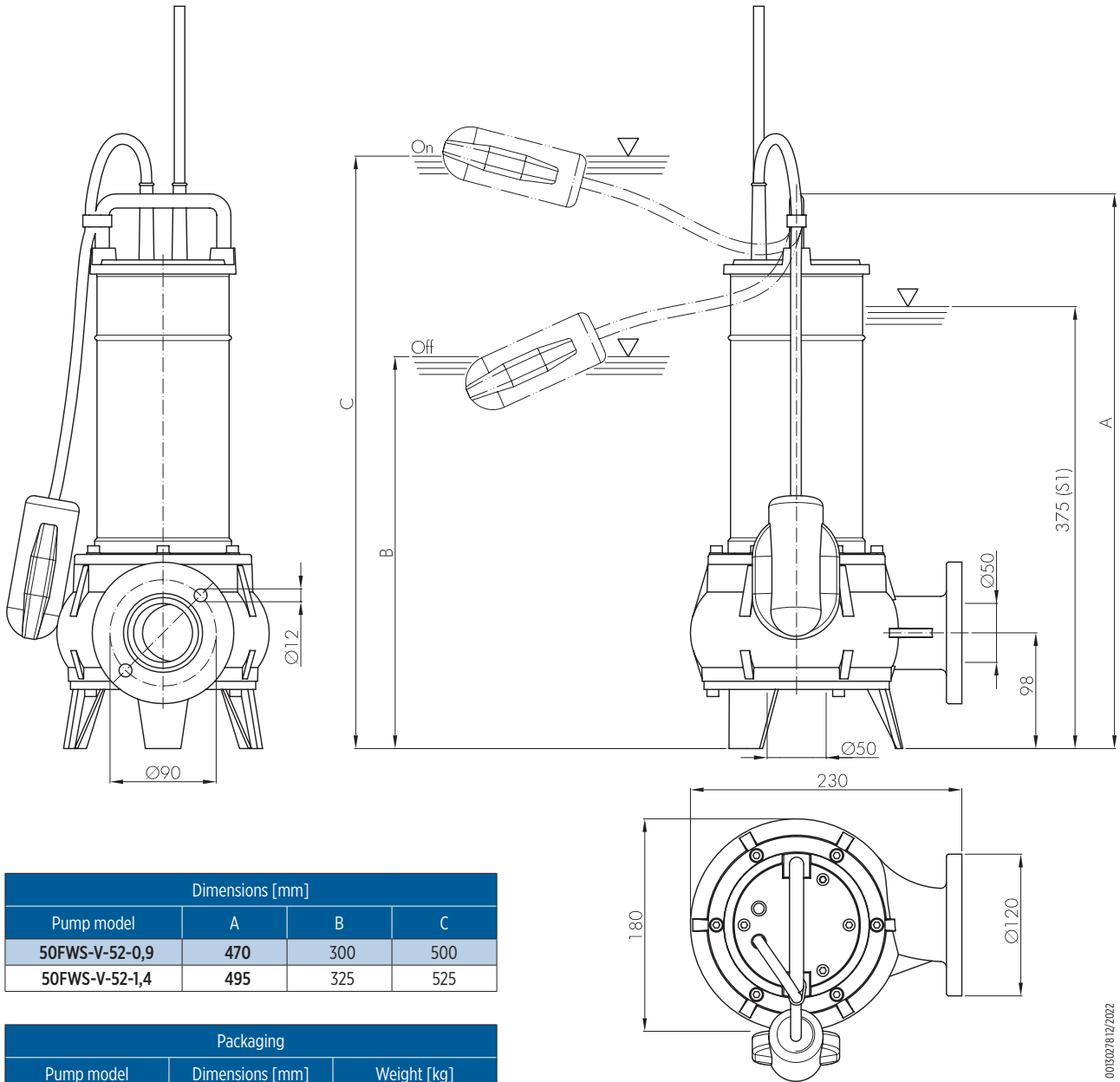

Dimensions [mm]			
Pump model	A	B	C
50FWS-V-52-0,9	470	300	500
50FWS-V-52-1,4	495	325	525

Packaging		
Pump model	Dimensions [mm]	Weight [kg]
50FWS-V-52-0,9	255x205x560	18,7
50FWS-V-52-1,4	255x205x560	19,7

0013027812/2022

TECHNICAL DATA

Pump model	Motor absorbed power P ₁	Rated power P ₂		Voltage [V]	Rated current [A]	Phase	Power cable		float switch	Running capacitor [µf]	Delivery port	Weight [kg]
	[kW]	[kW]	[HP]				length [m]	Type				
50FWS-V-52-0,9M	1,3	0,9	1,2	230	6	1 ~	10	3G1	-	20	G2	18
50FWS-V-52-0,9M-F	1,3	0,9	1,2	230	6	1 ~	10	3G1	-	20	Ø50	18
50FWS-V-52-0,9M-G	1,3	0,9	1,2	230	6	1 ~	10	3G1	•	20	G2	18
50FWS-V-52-0,9M-G-F	1,3	0,9	1,2	230	6	1 ~	10	3G1	•	20	Ø50	18
50FWS-V-52-0,9T	1,3	0,9	1,2	400	2	3 ~	10	4G1	-	-	G2	18
50FWS-V-52-0,9T-F	1,3	0,9	1,2	400	2	3 ~	10	4G1	-	-	Ø50	18
50FWS-V-52-0,9T-G	1,3	0,9	1,2	400	2	3 ~	10	4G1	•	-	G2	18
50FWS-V-52-0,9T-G-F	1,3	0,9	1,2	400	2	3 ~	10	4G1	•	-	Ø50	18
50FWS-V-52-1,4M	1,7	1,4	1,9	230	7,7	1 ~	10	3G1	-	25	G2	19
50FWS-V-52-1,4M-F	1,7	1,4	1,9	230	7,7	1 ~	10	3G1	-	25	Ø50	19
50FWS-V-52-1,4M-G	1,7	1,4	1,9	230	7,7	1 ~	10	3G1	•	25	G2	19
50FWS-V-52-1,4M-G-F	1,7	1,4	1,9	230	7,7	1 ~	10	3G1	•	25	Ø50	19
50FWS-V-52-1,4T	1,7	1,4	1,9	400	3,2	3 ~	10	4G1	-	-	G2	19
50FWS-V-52-1,4T-F	1,7	1,4	1,9	400	3,2	3 ~	10	4G1	-	-	Ø50	19

“-” = not available

• = available

HYDRAULIC PERFORMANCE AT 50 HZ

Pump model	Phase	Q = Delivery														
		l/sec 0	1	1,5	2	2,5	3	3,5	4	4,5	5	6	7	8	9	10
		m ³ /h 0	3,6	5,4	7,2	9	10,8	12,6	14,4	16,2	18	21,6	25,2	28,8	32,4	36
		US gpm 0	15,8	23,7	31,7	39,6	47,5	55,5	63,4	71,3	79,2	92,1	110,9	126,8	142,6	158,5
		H = Total meters head of water column [m]														
50FWS-V-52-0,9	1 ~	11	10,3	9,9	9,4	8,9	8,5	7,9	7,4	6,8	6,2	4,9	3,7	2,3	1,2	
	3 ~	11	10,3	9,9	9,4	8,9	8,5	7,9	7,4	6,8	6,2	4,9	3,7	2,3	1,2	
50FWS-V-52-1,4	1 ~	12	11,5	11,2	10,8	10,5	10,1	9,7	9,2	8,6	8	6,7	5,4	4	2,7	1,3
	3 ~	12	11,5	11,2	10,8	10,5	10,1	9,7	9,2	8,6	8	6,7	5,4	4	2,7	1,3

HYDRAULIC PERFORMANCE AT 50 HZ

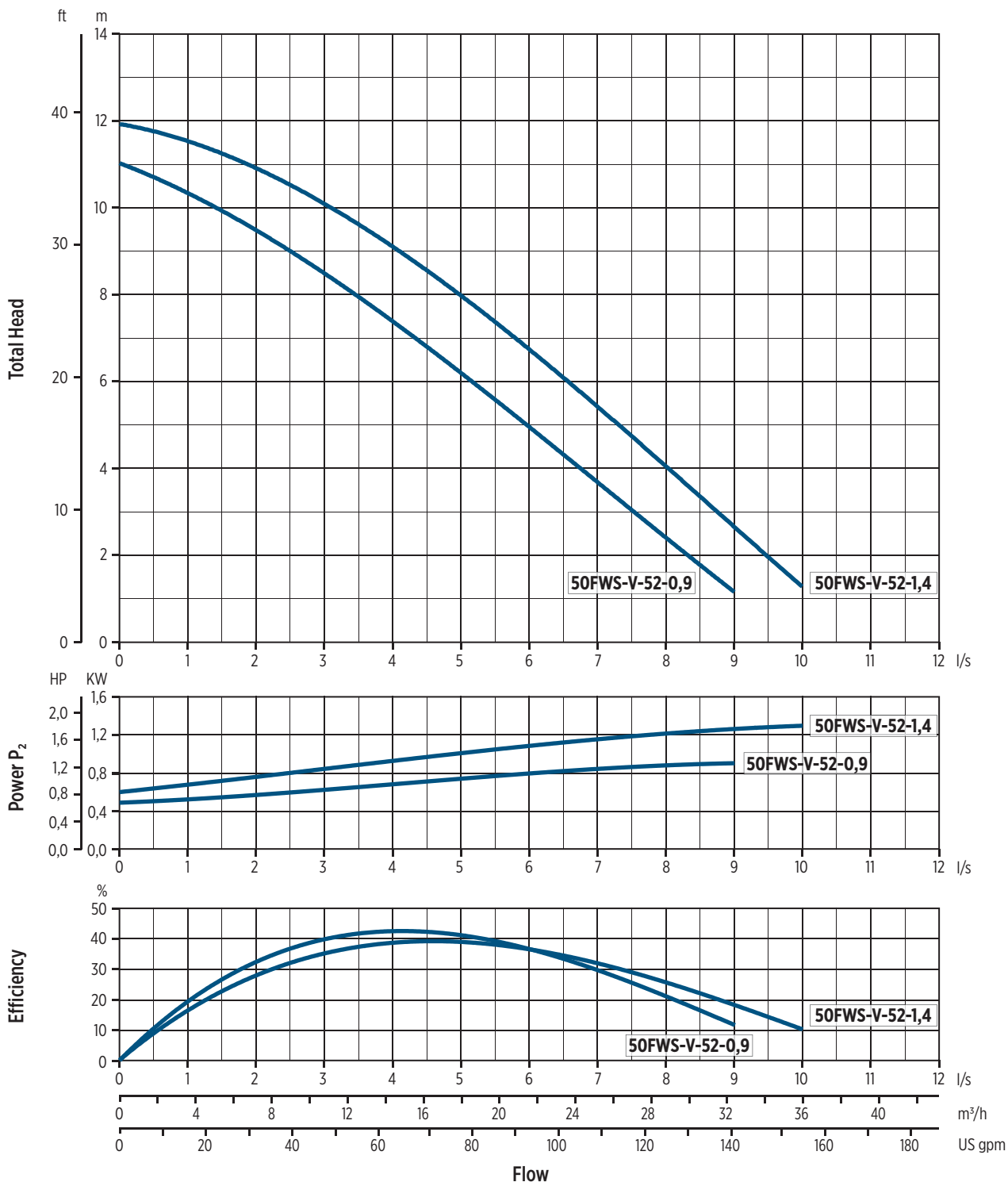

0020094.12/2022

INSTALLATION

INSTALLATION INSTRUCTIONS

PERMANENT INSTALLATION WITH COUPLING SYSTEM

It is the recommended installation for the permanent pumping station. The electric pump is guided by two pipes and it is connected automatically to the coupling system. The quick connection ensures that the pump can be easily removed and re-installed.

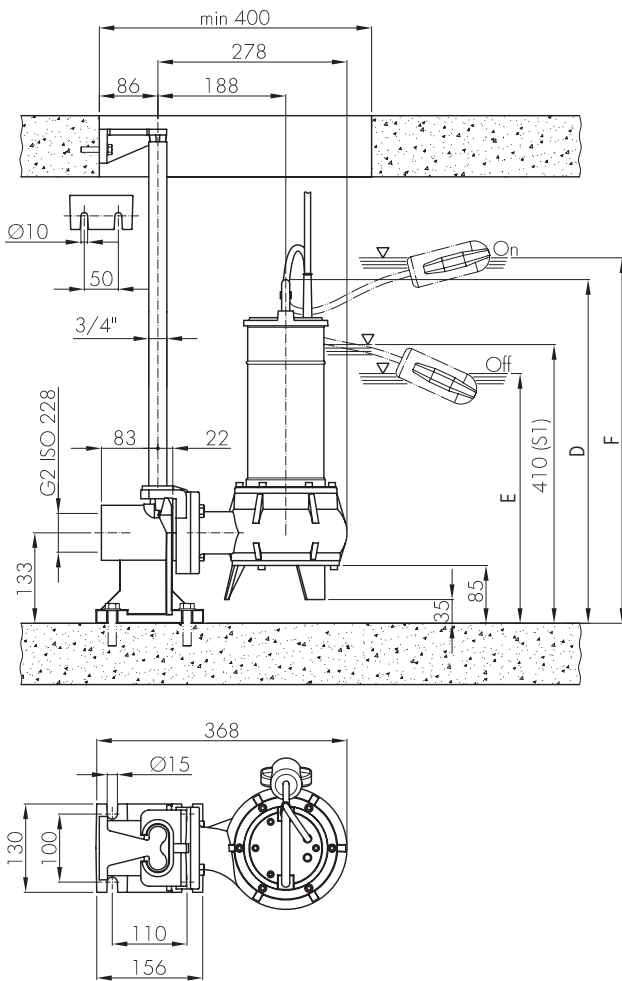

TRANSPORTABLE INSTALLATION

Transportable as emergency pump with connection to the hose and for free installation in the well.

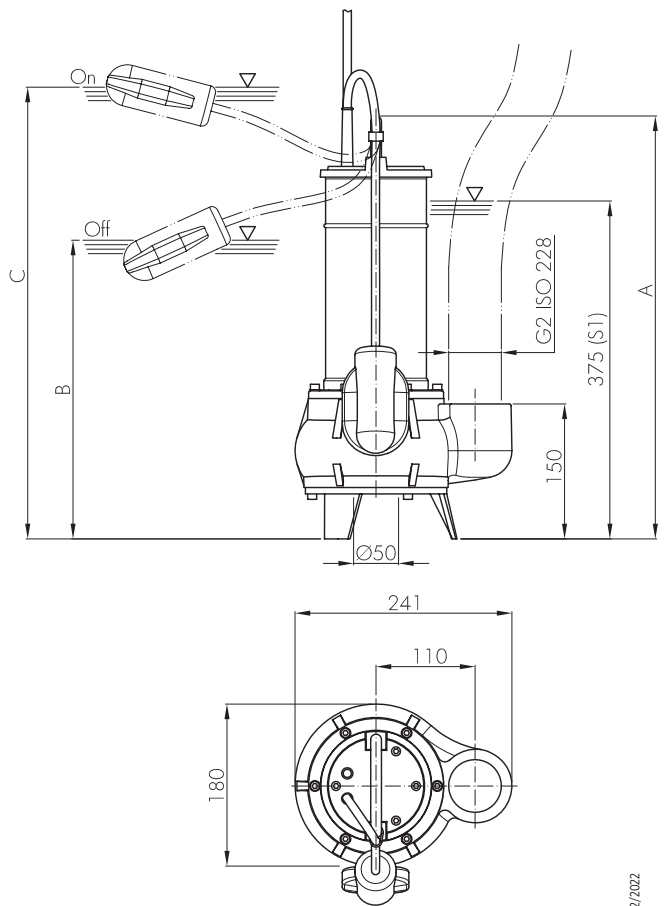

0030278 12/2022

Installation Dimensions [mm]						
Pump model	A	B	C	D	E	F
50FWS-V-52-0,9	470	300	500	505	335	535
50FWS-V-52-1,4	495	325	525	530	360	560

50FWC V SERIES 50 HZ

FEATURES & BENEFITS

APPLICATIONS



Pumping of clear non-loaded fluids



Extraction of water from ponds, streams or pits and for rainwater collection



Wastewater



MARKETS



CAST IRON SUBMERSIBLE WASTEWATER LIFT PUMPS

Submersible electric pumps suitable for pumping screened waste water, draining the sewage of blocks of flats and houses and flooded premises in general.

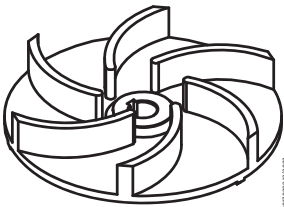

VORTEX IMPELLER

GENERAL FEATURES

		Materials/Constr.design
Vortex impeller		Cast iron EN GJL200
External casing		Cast iron EN GJL200
Pump body		Cast iron EN GJL200
Cover		Cast iron EN GJL200
Mechanical seal		Silicon carbide (SiC/SiC)
Motor shaft		Stainless steel AISI416
Power cable	Type	10 m H07RN-F type
	Single-phase	4G1,5mm ² , capacitor box and SCHUKO plug (CEE 7/VII)
	Single-phase 50FWC-V-52-1,6M	4G2,5mm ² , capacitor box and SCHUKO plug (CEE 7/VII)
	Three-phase	4G1,5mm ²
		Motor
Constr.design		asynchronous squirrel cage-type oil filled
Type		2 poles; 50 Hz
Insulation class		F
Protection degree		IP68
Voltage	Single-phase	230V ±6% built-in overheating protection (up to 1,1 kW), float switch as optional
	Three-phase	230V ±10%, 400V ±10%
		Limits of use
Maximum liquid temperature		+40 °C
pH of pumped liquid		6 - 10
Liquid density		1,0 kg/dm ³
Maximum immersion depth:		5 m
Min. immersion depth for continuous service		
50FWC-V-52-0,9M/T, 50FWC-V-52-1,1M/T		353 mm
50FWC-V-52-1,6M/T		380 mm
Free passage	50FWC-V-52-0,9M/T, 50FWC-V-52-1,1M/T	40 mm
	50FWC-V-52-1,6M/T	50 mm
Max. number of starting/hour		20
		Construction options

- 60 Hz version
- Different voltages
- Food-grade white oil

DIMENSIONAL DRAWINGS

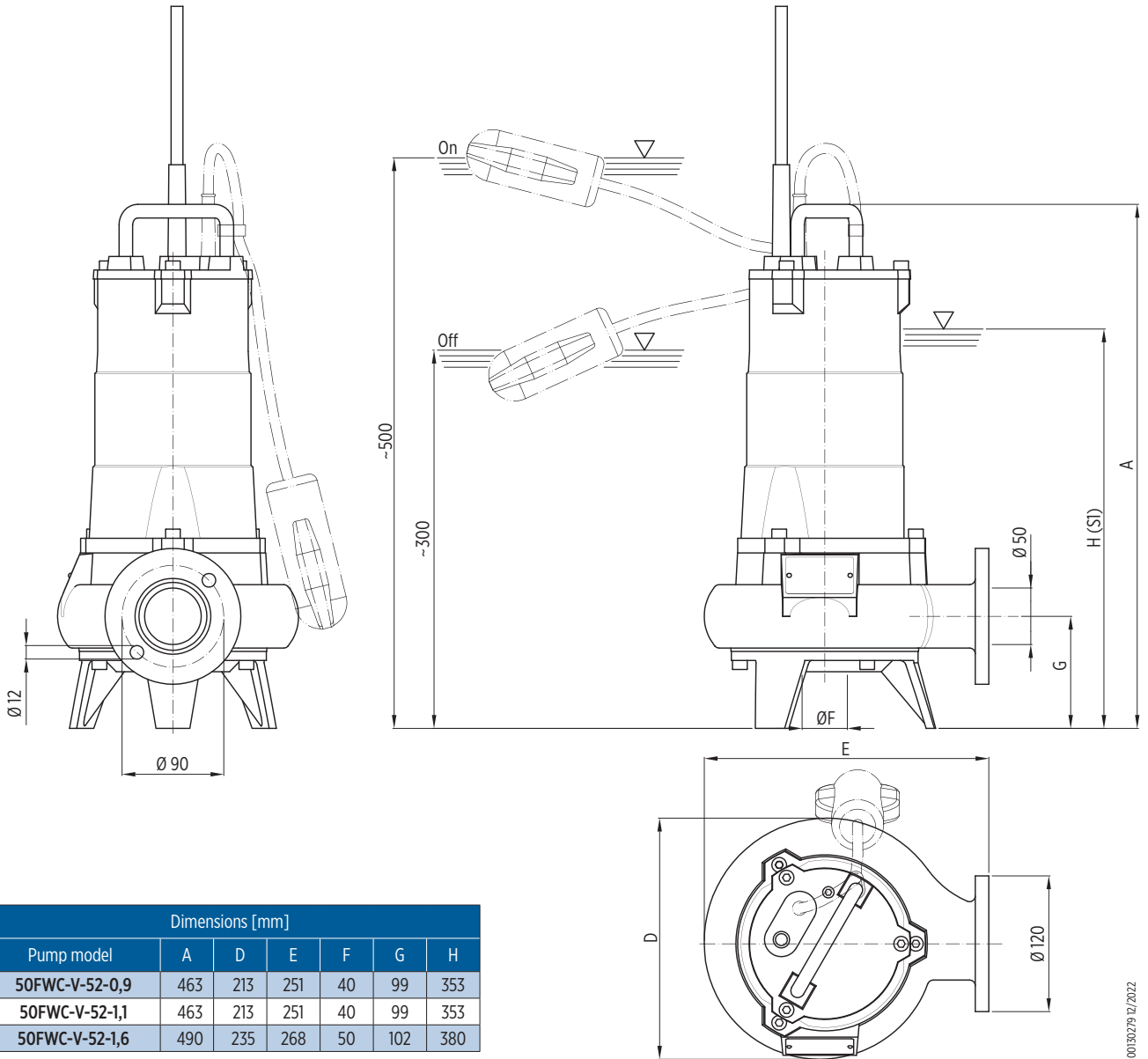

Dimensions [mm]						
Pump model	A	D	E	F	G	H
50FWC-V-52-0,9	463	213	251	40	99	353
50FWC-V-52-1,1	463	213	251	40	99	353
50FWC-V-52-1,6	490	235	268	50	102	380

Packaging		
Pump model	Dimensions [mm]	Weight [kg]
50FWC-V-52-0,9	290x245x585	30
50FWC-V-52-1,1	290x245x585	30
50FWC-V-52-1,6	300x260x585	36

00130279 12/2022

TECHNICAL DATA

Pump model	Motor absorbed power P ₁	Rated power P ₂		Voltage	Rated current	Phase	Power cable		float switch	Running capacitor	Delivery port	Weight [kg]
	[kW]	[kW]	[HP]	[V]	[A]		length [m]	Type		[µf]		
50FWC-V-52-0,9M	1,3	0,9	1,2	230	5,8	1 ~	10	4G1,5	-	25	G2 (Ø50)	29
50FWC-V-52-0,9M-G	1,3	0,9	1,2	230	5,8	1 ~	10	4G1,5	•	25	G2 (Ø50)	29
50FWC-V-52-0,9T	1,3	0,9	1,2	400	2	3 ~	10	4G1,5	-	-	G2 (Ø50)	29
50FWC-V-52-0,9T-G	1,3	0,9	1,2	400	2	3 ~	10	4G1,5	•	-	G2 (Ø50)	29
50FWC-V-52-1,1M	1,7	1,1	1,5	230	7	1 ~	10	4G1,5	-	30	G2 (Ø50)	29
50FWC-V-52-1,1M-G	1,7	1,1	1,5	230	7	1 ~	10	4G1,5	•	30	G2 (Ø50)	29
50FWC-V-52-1,1T	1,7	1,1	1,5	400	3	3 ~	10	4G1,5	-	-	G2 (Ø50)	29
50FWC-V-52-1,1T-G	1,7	1,1	1,5	400	3	3 ~	10	4G1,5	•	-	G2 (Ø50)	29
50FWC-V-52-1,6M	2,3	1,6	2,1	230	9,1	1 ~	10	4G2,5	-	40	G2 (Ø50)	35
50FWC-V-52-1,6M-G	2,3	1,6	2,1	230	9,1	1 ~	10	4G2,5	•	40	G2 (Ø50)	35
50FWC-V-52-1,6T	2,3	1,6	2,1	400	4	3 ~	10	4G1,5	-	-	G2 (Ø50)	35
50FWC-V-52-1,6T-G	2,3	1,6	2,1	400	4	3 ~	10	4G1,5	•	-	G2 (Ø50)	35

"-" = not available

• = available

HYDRAULIC PERFORMANCE AT 50 HZ

Pump model	Phase	Q = Delivery										
		l/sec 0	1	2	3	4	5	6	7	8	9	10
		m ³ /h 0	3,6	7,2	10,8	14,4	18	21,6	25,2	28,8	32,4	36
		US gpm 0	15,8	31,7	47,5	63,4	79,2	92,1	110,9	126,8	142,6	158,5
		H = Total meters head of water column [m]										
50FWC-V-52-0,9	1 ~	12,2	11	9,8	8,5	7,4	6	4,3	2,3			
	3 ~	12,2	11	9,8	8,5	7,4	6	4,3	2,3			
50FWC-V-52-1,1	1 ~	13	12	11	9,5	8,3	7	5,7	4,4	3	1,6	
	3 ~	13	12	11	9,5	8,3	7	5,7	4,4	3	1,6	
50FWC-V-52-1,6	1 ~	14	12,5	11,5	10,5	9,6	8,7	7,8	6,8	5,5	4	2,1
	3 ~	14	12,5	11,5	10,5	9,6	8,7	7,8	6,8	5,5	4	2,1

HYDRAULIC PERFORMANCE AT 50 HZ

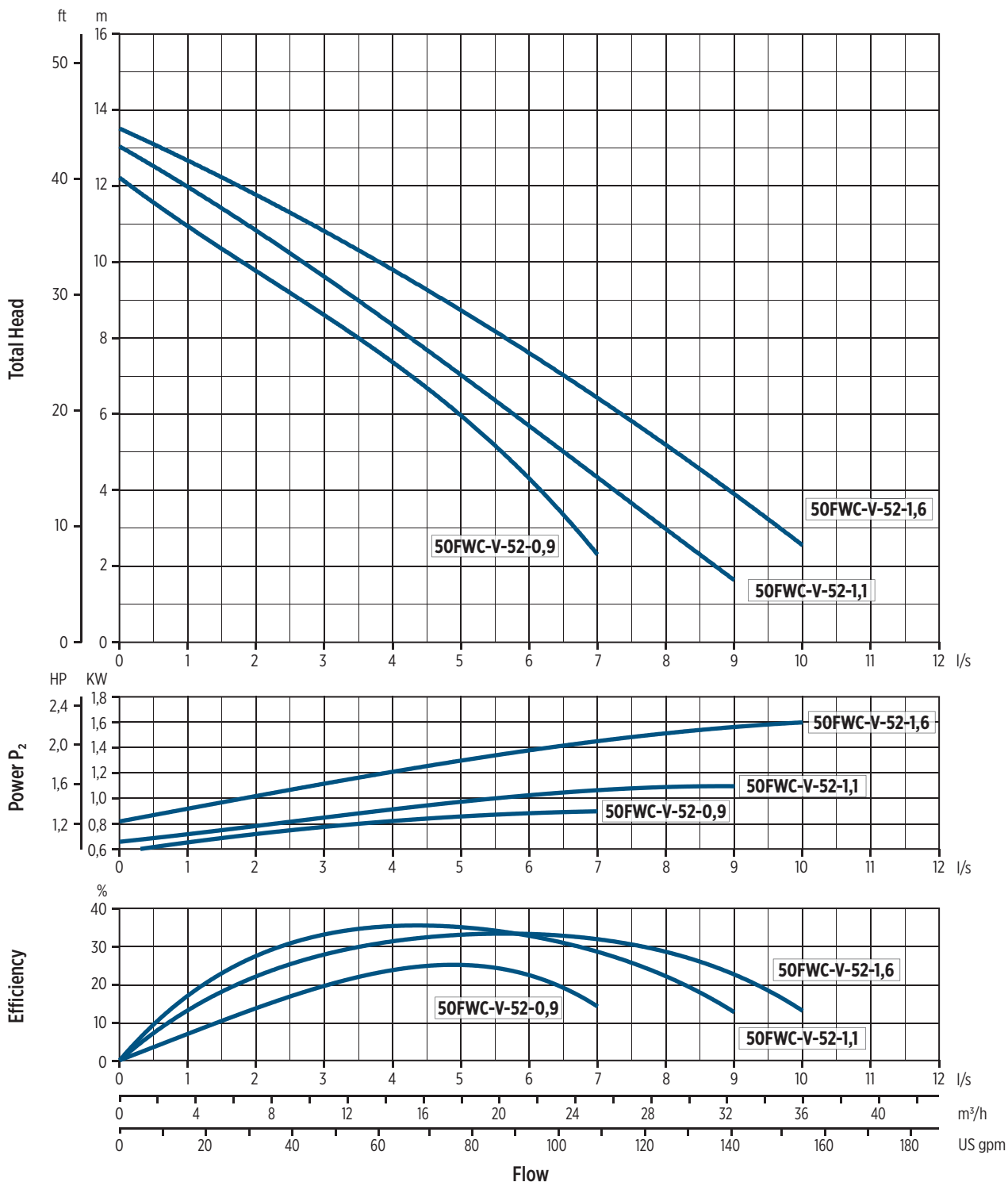

0020095 12/2022

INSTALLATION

INSTALLATION INSTRUCTIONS

PERMANENT INSTALLATION WITH COUPLING SYSTEM

It is the recommended installation for the permanent pumping station. The electric pump is guided by two pipes and it is connected automatically to the coupling system. The quick connection ensures that the pump can be easily removed and re-installed.

TRANSPORTABLE INSTALLATION

Transportable as emergency pump with connection to the hose and for free installation in the well.

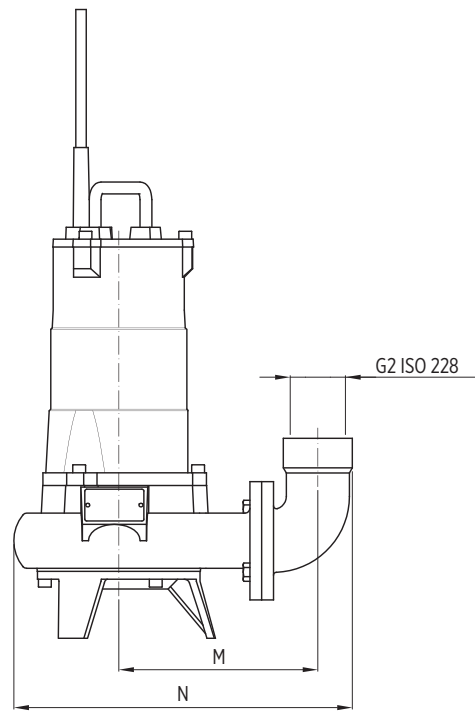
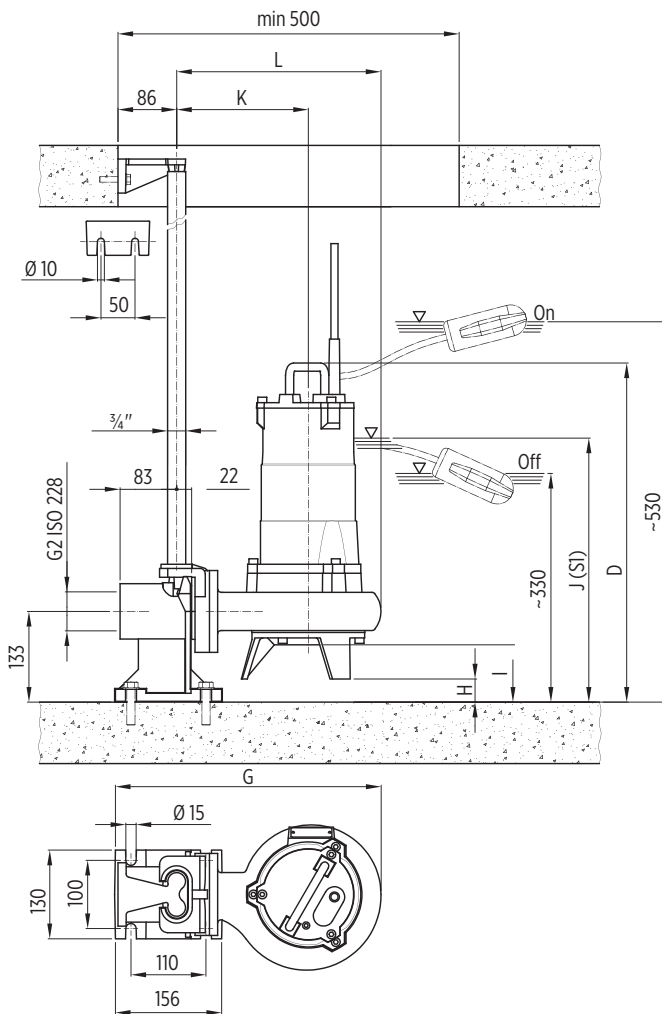

00130279/12/2022

Installation Dimensions [mm]

Pump model	D	G	H	I	J	K	L	M	N
50FWC-V-52-0,9	497	390	34	84	387	193	300	202	344
50FWC-V-52-1,1	497	390	34	84	387	193	300	202	344
50FWC-V-52-1,6	521	407	31	81	414	200	316	209	360

50FWC M SERIES 50 HZ

FEATURES & BENEFITS

APPLICATIONS



Pumping of clear non-loaded fluids



Extraction of water from ponds, streams or pits and for rainwater collection



Wastewater



MARKETS



CAST IRON SUBMERSIBLE WASTEWATER LIFT PUMPS

Submersible electric pumps suitable for pumping screened waste water, draining the sewage of blocks of flats and houses and flooded premises in general.

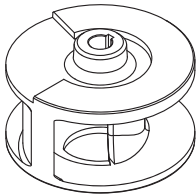

0000017/2022

SINGLE-CHANNEL IMPELLER

GENERAL FEATURES

		Materials/Constr.design
Single-channel impeller		Cast iron EN GJL200
External casing		Cast iron EN GJL200
Pump body		Cast iron EN GJL200
Cover		Cast iron EN GJL200
Mechanical seal		Silicon carbide (SiC/SiC)
Motor shaft		Stainless steel AISI416
Power cable	Type	10 m H07RN-F type
	Single-phase	4G1,5mm ² , capacitor box and SCHUKO plug (CEE 7/VII)
	Single-phase 50FWC-M-52-1,6M	4G2,5mm ² , capacitor box and SCHUKO plug (CEE 7/VII)
	Three-phase	4G1,5mm ²
		Motor
Constr.design		asynchronous squirrel cage-type oil filled
Type		2 poles; 50 Hz
Insulation class		F
Protection degree		IP68
Voltage	Single-phase	230V ±6% built-in overheating protection, float switch as optional
	Three-phase	230V ±10%, 400V ±10%
		Limits of use
Maximum liquid temperature		+40 °C
pH of pumped liquid		6 - 10
Liquid density		1,0 kg/dm ³
Maximum immersion depth:		5 m
Min. immersion depth for continuous service		
50FWC-M-52-0,9M/T, 50FWC-M-52-1,1M/T		353 mm
50FWC-M-52-1,6M/T, 50FWC-M-52-1,6T-HH		380 mm
Free passage	50FWC-M-52-0,9M/T, 50FWC-M-52-1,1M/T	40 mm
	50FWC-M-52-1,6M/T, 50FWC-M-52-1,6T-HH	50 mm
Max. number of starting/hour		20
		Construction options

- 60 Hz version
- Different voltages
- Food-grade white oil

DIMENSIONAL DRAWINGS

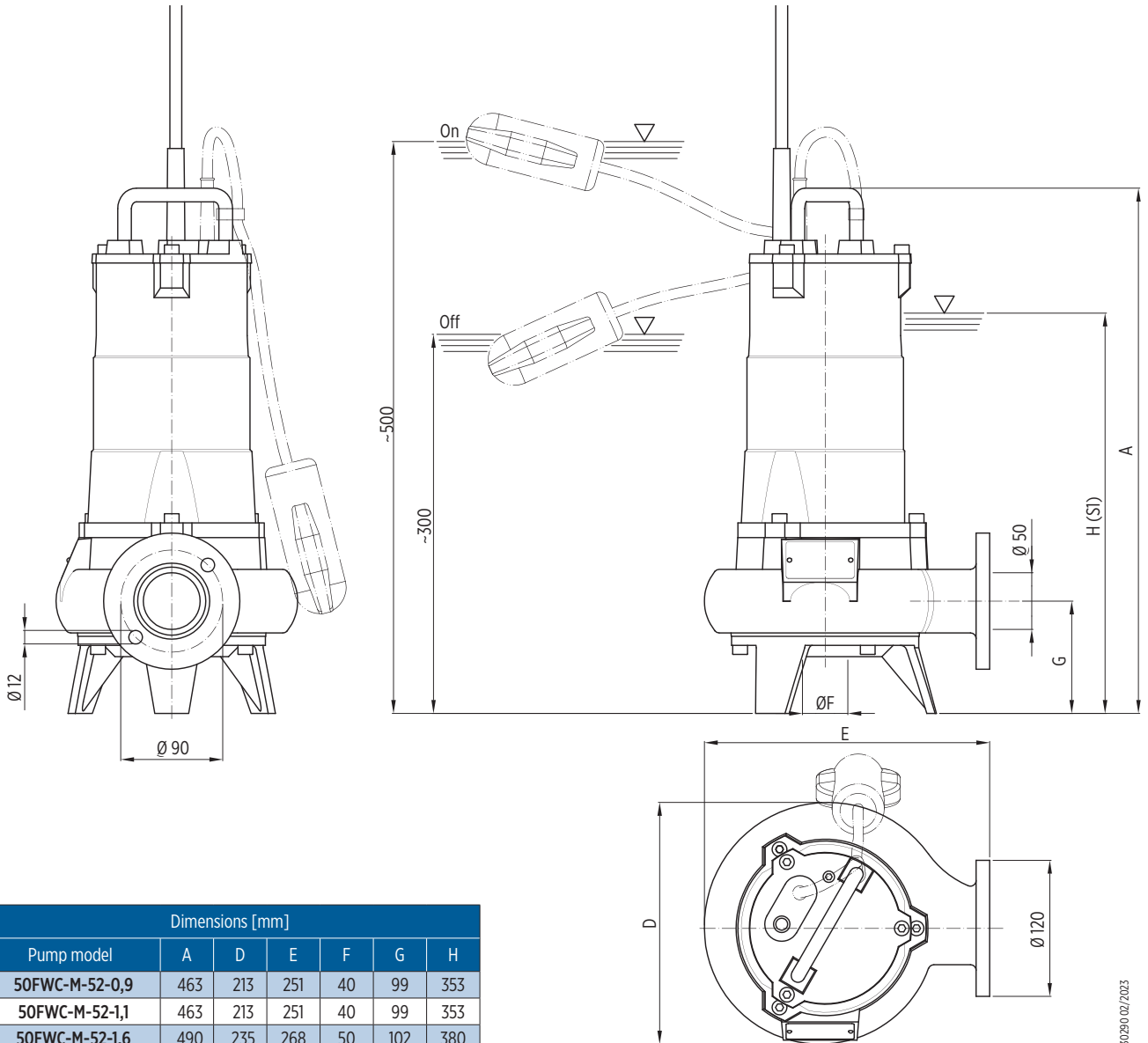

00150290 02/2023

Dimensions [mm]

Pump model	A	D	E	F	G	H
50FWC-M-52-0,9	463	213	251	40	99	353
50FWC-M-52-1,1	463	213	251	40	99	353
50FWC-M-52-1,6	490	235	268	50	102	380

Packaging

Pump model	Dimensions [mm]	Weight [kg]
50FWC-M-52-0,9	290x245x585	31
50FWC-M-52-1,1	290x245x585	31
50FWC-M-52-1,6	300x260x585	35

TECHNICAL DATA

Pump model	Motor absorbed power P ₁	Rated power P ₂		Voltage	Rated current	Phase	Power cable		float switch	Running capacitor	Delivery port	Weight [kg]
	[kW]	[kW]	[HP]	[V]	[A]		length [m]	Type		[µf]		
50FWC-M-52-0,9M	1,3	0,9	1,2	230	5,8	1 ~	10	4G1,5	-	25	G2 (Ø50)	30
50FWC-M-52-0,9M-G	1,3	0,9	1,2	230	5,8	1 ~	10	4G1,5	•	25	G2 (Ø50)	30
50FWC-M-52-0,9T	1,3	0,9	1,2	400	2	3 ~	10	4G1,5	-	-	G2 (Ø50)	30
50FWC-M-52-0,9T-G	1,3	0,9	1,2	400	2	3 ~	10	4G1,5	•	-	G2 (Ø50)	30
50FWC-M-52-1,1M	1,7	1,1	1,5	230	7	1 ~	10	4G1,5	-	30	G2 (Ø50)	30
50FWC-M-52-1,1M-G	1,7	1,1	1,5	230	7	1 ~	10	4G1,5	•	30	G2 (Ø50)	30
50FWC-M-52-1,1T	1,6	1,1	1,5	400	3	3 ~	10	4G1,5	-	-	G2 (Ø50)	30
50FWC-M-52-1,1T-G	1,6	1,1	1,5	400	3	3 ~	10	4G1,5	•	-	G2 (Ø50)	30
50FWC-M-52-1,6M	2,3	1,6	2,1	230	11	1 ~	10	4G2,5	-	40	G2 (Ø50)	34
50FWC-M-52-1,6M-G	2,3	1,6	2,1	230	11	1 ~	10	4G2,5	•	40	G2 (Ø50)	34
50FWC-M-52-1,6T	2,2	1,6	2,1	400	4	3 ~	10	4G1,5	-	-	G2 (Ø50)	34
50FWC-M-52-1,6T-HH	2,2	1,6	2,1	400	4,2	3 ~	10	4G1,5	-	-	G2 (Ø50)	34
50FWC-M-52-1,6T-G	2,2	1,6	2,1	400	4	3 ~	10	4G1,5	•	-	G2 (Ø50)	34

"-" = not available

• = available

HYDRAULIC PERFORMANCE AT 50 HZ

Pump model	Phase	Q = Delivery													
		l/sec 0	1	2	3	4	5	6	7	8	9	10	12	13	14
		m ³ /h 0	3,6	7,2	10,8	14,4	18	21,6	25,2	28,8	32,4	36	43,2	46,8	50,4
		US gpm 0	15,8	31,7	47,5	63,4	79,2	92,1	110,9	126,8	142,6	158,5	190,2	206	221,9
		H = Total meters head of water column [m]													
50FWC-M-52-0,9	1 ~	15,5	12,5	11	9,5	8,3	7	5,6	4,1	2,5					
	3 ~	15,5	12,5	11	9,5	8,3	7	5,6	4,1	2,5					
50FWC-M-52-1,1	1 ~	17,5	15	13,5	12	10,5	9,4	8	6,5	5	3,4	1,7			
	3 ~	17,5	15	13,5	12	10,5	9,4	8	6,5	5	3,4	1,7			
50FWC-M-52-1,6	1 ~	19	17	15,5	14	13	12	11	10	9,4	8,6	7,7	5,8	4,2	2,5
	3 ~	19	17	15,5	14	13	12	11	10	9,4	8,6	7,7	5,8	4,2	2,5
	3 - HH	24	22	20,5	19	17,5	16,5	15,2	14	13					

HYDRAULIC PERFORMANCE AT 50 HZ

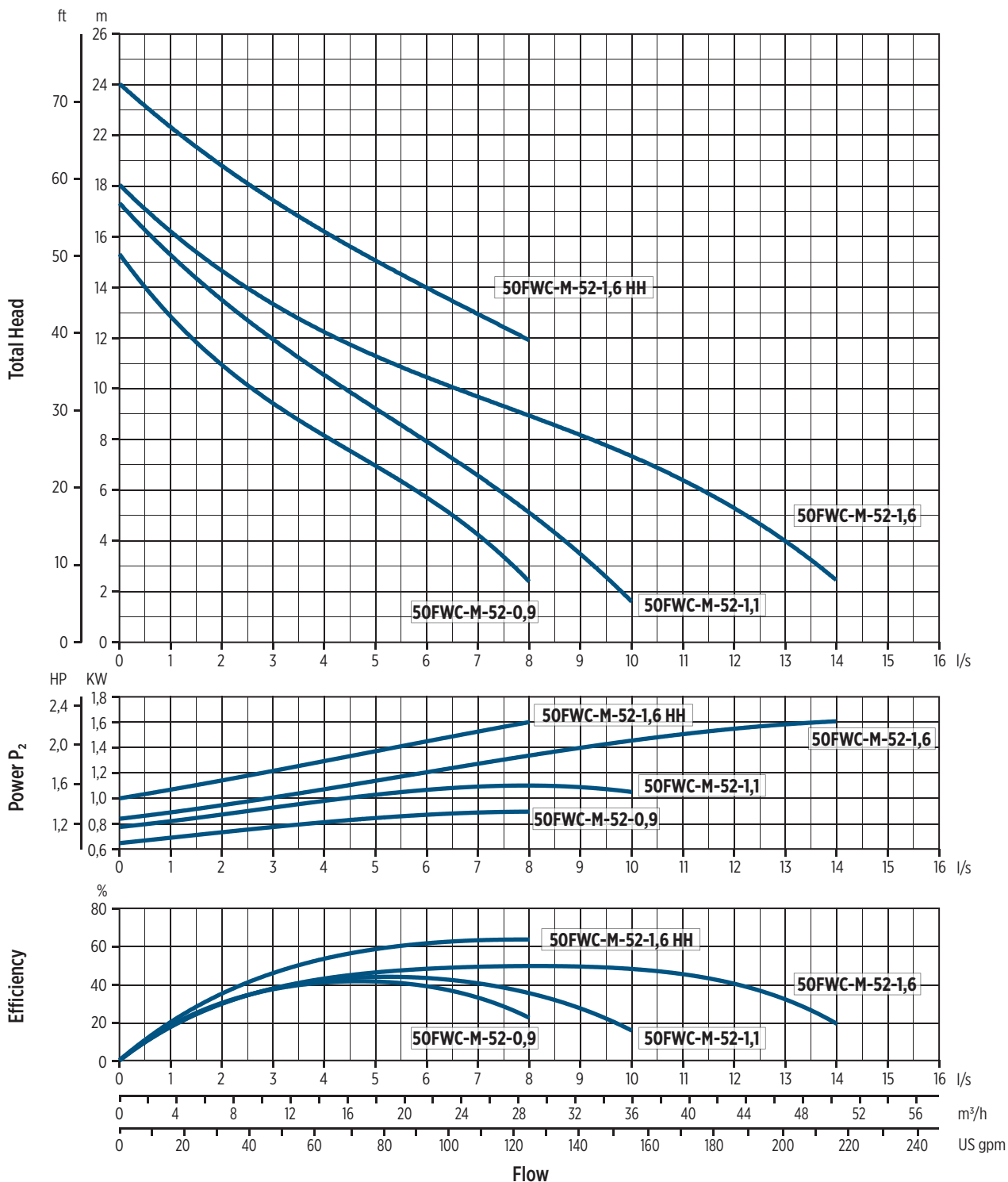

00202005 02/2023

INSTALLATION

INSTALLATION INSTRUCTIONS

PERMANENT INSTALLATION WITH COUPLING SYSTEM

It is the recommended installation for the permanent pumping station. The electric pump is guided by two pipes and it is connected automatically to the coupling system. The quick connection ensures that the pump can be easily removed and re-installed.

TRANSPORTABLE INSTALLATION

Transportable as emergency pump with connection to the hose and for free installation in the well.

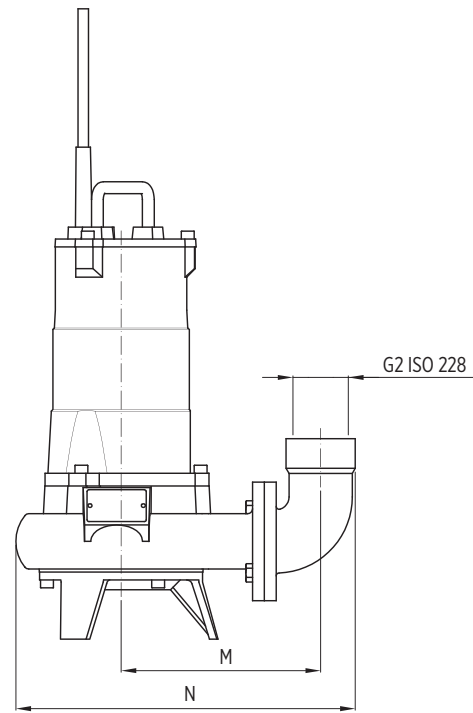
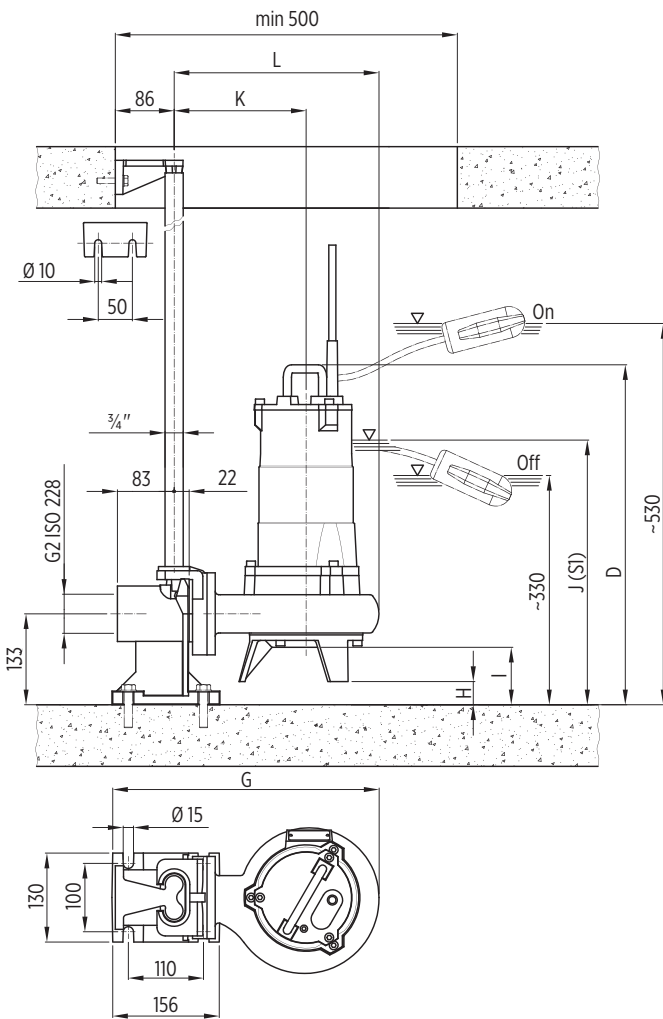

00130290-02/2023

Installation Dimensions [mm]

Pump model	D	G	H	I	J	K	L	M	N
50FWC-M-52-0,9	497	390	34	84	387	193	300	202	344
50FWC-M-52-1,1	497	390	34	84	387	193	300	202	344
50FWC-M-52-1,6	521	407	31	81	414	200	316	209	360

50FWC V4 SERIES 50 HZ

FEATURES & BENEFITS

APPLICATIONS



Pumping of clear non-loaded fluids



Extraction of water from ponds, streams or pits and for rainwater collection



Wastewater



MARKETS



CAST IRON SUBMERSIBLE WASTEWATER LIFT PUMPS

Submersible electric pumps suitable for pumping screened waste water, draining the sewage of blocks of flats and houses and flooded premises in general.

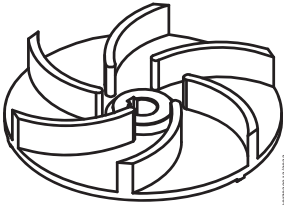

VORTEX IMPELLER

GENERAL FEATURES

		Materials/Constr.design
Vortex impeller		Cast iron EN GJL200
External casing		Cast iron EN GJL200
Pump body		Cast iron EN GJL200
Cover		Cast iron EN GJL200
Mechanical seal		Silicon carbide (SiC/SiC)
Motor shaft		Stainless steel AISI416
Power cable	Type	10 m H07RN-F type
	Single-phase 50FWC-V-52-1,6M	4G2,5mm ² , capacitor box and SCHUKO plug (CEE 7/VII)
	Three-phase	4G1,5mm ²
		Motor
Constr.design		asynchronous squirrel cage-type oil filled
Type		4 poles; 50 Hz
Insulation class		F
Protection degree		IP68
Voltage	Single-phase	230V ±6% built-in overheating protection (up to 1,1 kW), float switch as optional
	Three-phase	230V ±10%, 400V ±10%
		Limits of use
Maximum liquid temperature		+40 °C
pH of pumped liquid		6 - 10
Liquid density		1,0 kg/dm ³
Maximum immersion depth:		5 m
Min. immersion depth for continuous service		
50FWC-V-54-0,75M/T		353 mm
50FWC-V-54-1,1M/T		380 mm
Free passage	50FWC-V-54-0,75M/T	40 mm
	50FWC-V-54-1,1M/T	50 mm
Max. number of starting/hour		20
		Construction options

- 60 Hz version
- Different voltages
- Food-grade white oil

DIMENSIONAL DRAWINGS

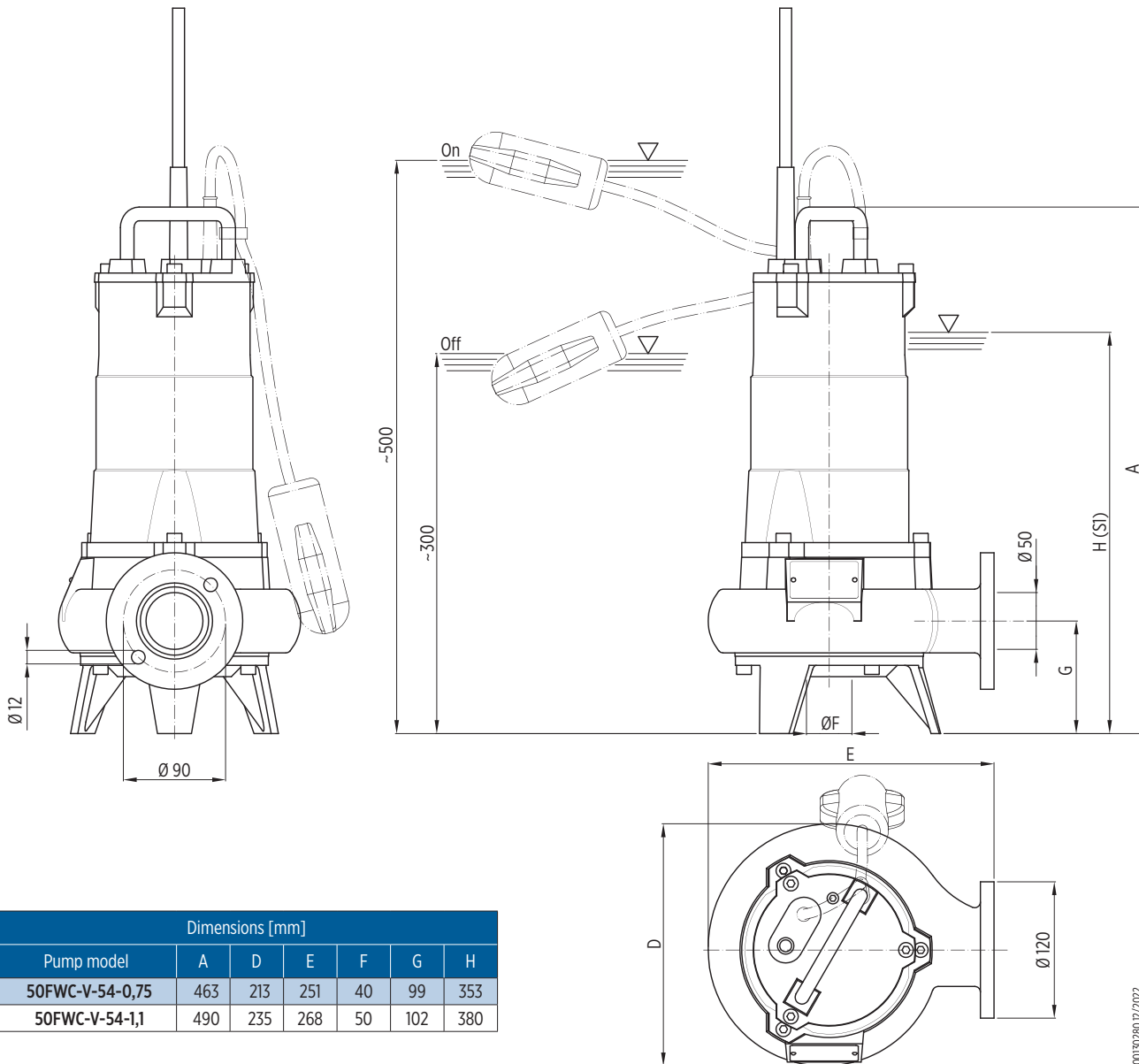

00130280.12/2022

Dimensions [mm]						
Pump model	A	D	E	F	G	H
50FWC-V-54-0,75	463	213	251	40	99	353
50FWC-V-54-1,1	490	235	268	50	102	380

Packaging		
Pump model	Dimensions [mm]	Weight [kg]
50FWC-V-54-0,75	290x245x585	30
50FWC-V-54-1,1	300x260x585	34

TECHNICAL DATA

Pump model	Motor absorbed power P ₁	Rated power P ₂		Voltage	Rated current	Phase	Power cable		float switch	Running capacitor	Delivery port	Weight [kg]
	[kW]	[kW]	[HP]	[V]	[A]		length [m]	Type		[µf]		
50FWC-V-54-0,75M	1,2	0,75	1	230	5	1 ~	10	4G1,5	-	14	G2 (Ø50)	29
50FWC-V-54-0,75M-G	1,2	0,75	1	230	5	1 ~	10	4G1,5	•	14	G2 (Ø50)	29
50FWC-V-54-0,75T	1,2	0,75	1	400	1,9	3 ~	10	4G1,5	-	-	G2 (Ø50)	29
50FWC-V-54-0,75T-G	1,2	0,75	1	400	1,9	3 ~	10	4G1,5	•	-	G2 (Ø50)	29
50FWC-V-54-1,1M	1,5	1,1	1,5	230	7,7	1 ~	10	4G1,5	-	20	G2 (Ø50)	33
50FWC-V-54-1,1M-G	1,5	1,1	1,5	230	7,7	1 ~	10	4G1,5	•	20	G2 (Ø50)	33
50FWC-V-54-1,1T	1,5	1,1	1,5	400	2,8	3 ~	10	4G1,5	-	-	G2 (Ø50)	33
50FWC-V-54-1,1T-G	1,5	1,1	1,5	400	2,8	3 ~	10	4G1,5	•	-	G2 (Ø50)	33

"-" = not available

• = available

HYDRAULIC PERFORMANCE AT 50 HZ

Pump model	Phase	Q = Delivery											
		l/sec 0	1	2	3	4	5	6	7	8	9	10	11
		m ³ /h 0	3,6	7,2	10,8	14,4	18	21,6	25,2	28,8	32,4	36	39,6
		US gpm 0	15,8	31,7	47,5	63,4	79,2	92,1	110,9	126,8	142,6	158,5	174,3
50FWC-V-54-0,75	1 ~	6,4	6,2	5,8	5,3	4,6	3,8	2,8	1,8				
	3 ~	6,4	6,2	5,8	5,3	4,6	3,8	2,8	1,8				
50FWC-V-54-1,1	1 ~	7,4	7	6,6	6,2	5,8	5,4	4,9	4,4	3,9	3,3	2,5	1,6
	3 ~	7,4	7	6,6	6,2	5,8	5,4	4,9	4,4	3,9	3,3	2,5	1,6

HYDRAULIC PERFORMANCE AT 50 HZ

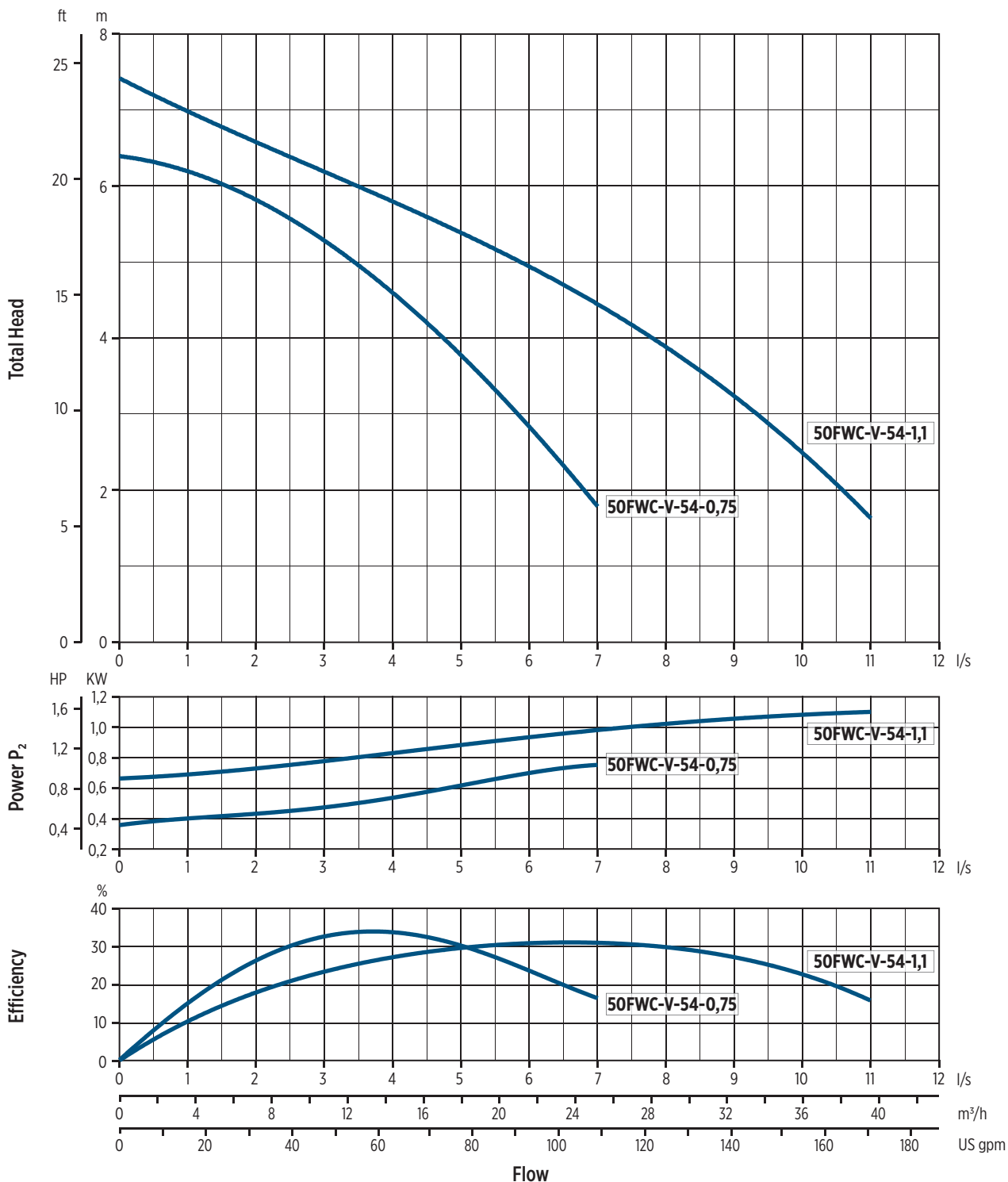

0070096 05/2023

INSTALLATION

INSTALLATION INSTRUCTIONS

PERMANENT INSTALLATION WITH COUPLING SYSTEM

It is the recommended installation for the permanent pumping station. The electric pump is guided by two pipes and it is connected automatically to the coupling system. The quick connection ensures that the pump can be easily removed and re-installed.

TRANSPORTABLE INSTALLATION

Transportable as emergency pump with connection to the hose and for free installation in the well.

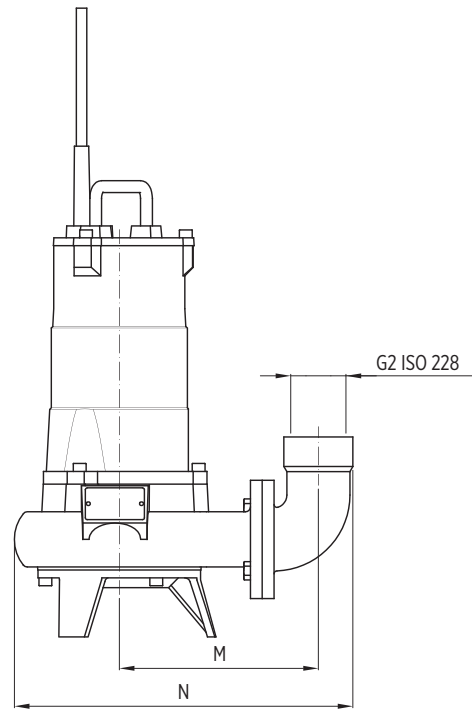
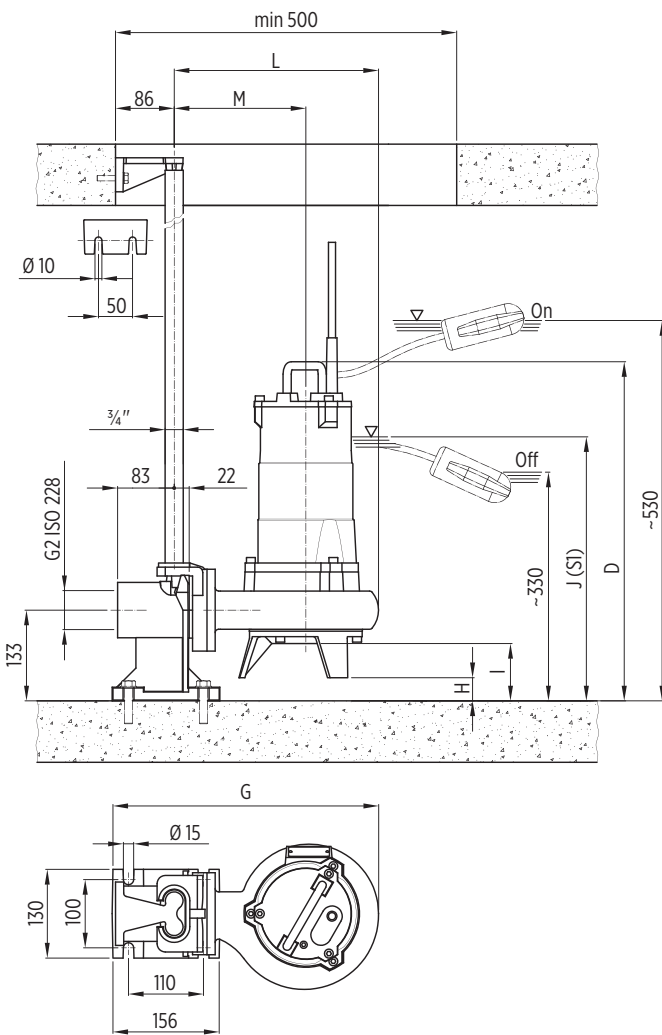

00130286 12/2022

Installation Dimensions [mm]

Pump model	D	G	H	I	J	K	L	M	N
50FWC-V-54-0,75	497	390	34	84	387	193	300	202	344
50FWC-V-54-1,1	521	407	31	81	414	200	316	209	360

65FWC V SERIES 50 HZ

FEATURES & BENEFITS

APPLICATIONS



Domestic / industrial grey water



Extraction of water from ponds, streams or pits and for rainwater collection



Wastewater



MARKETS



RESIDENTIAL



COMMERCIAL



INDUSTRY



AGRICULTURE

CAST IRON SUBMERSIBLE WASTEWATER LIFT PUMPS

Submersible electric pumps particularly suitable for pumping industrial sewage, screened waste water and mud in the pumping stations. They can be used also to lift clear and dirty water and rain water.

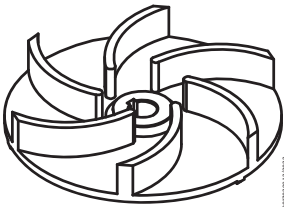

VORTEX IMPELLER

GENERAL FEATURES

		Materials/Constr.design
Vortex impeller		Cast iron EN GJL200
External casing		Cast iron EN GJL200
Pump body		Cast iron EN GJL200
Cover		Cast iron EN GJL200
Mechanical seal	motor side	Seal ring
	pump side	Silicon carbide (SiC/SiC)
Motor shaft		Stainless steel AISI420
Power cable		10 m H07RN-F type, 4G1,5mm ²
		Motor
Constr.design		asynchronous squirrel cage-type oil filled
Type		2 poles; 50 Hz
Insulation class		F
Protection degree		IP68
Voltage	Three-phase	230V ±10%, 400V ±10%
		Limits of use
Maximum liquid temperature		+40 °C
pH of pumped liquid		6 - 10
Liquid density		1,0 kg/dm ³
Maximum immersion depth:		5 m
Min. immersion depth for continuous service		464 mm
Free passage		65 mm
Max. number of starting/hour		20
		Construction options

- 60 Hz version
- Different voltages
- Food-grade white oil

DIMENSIONAL DRAWINGS

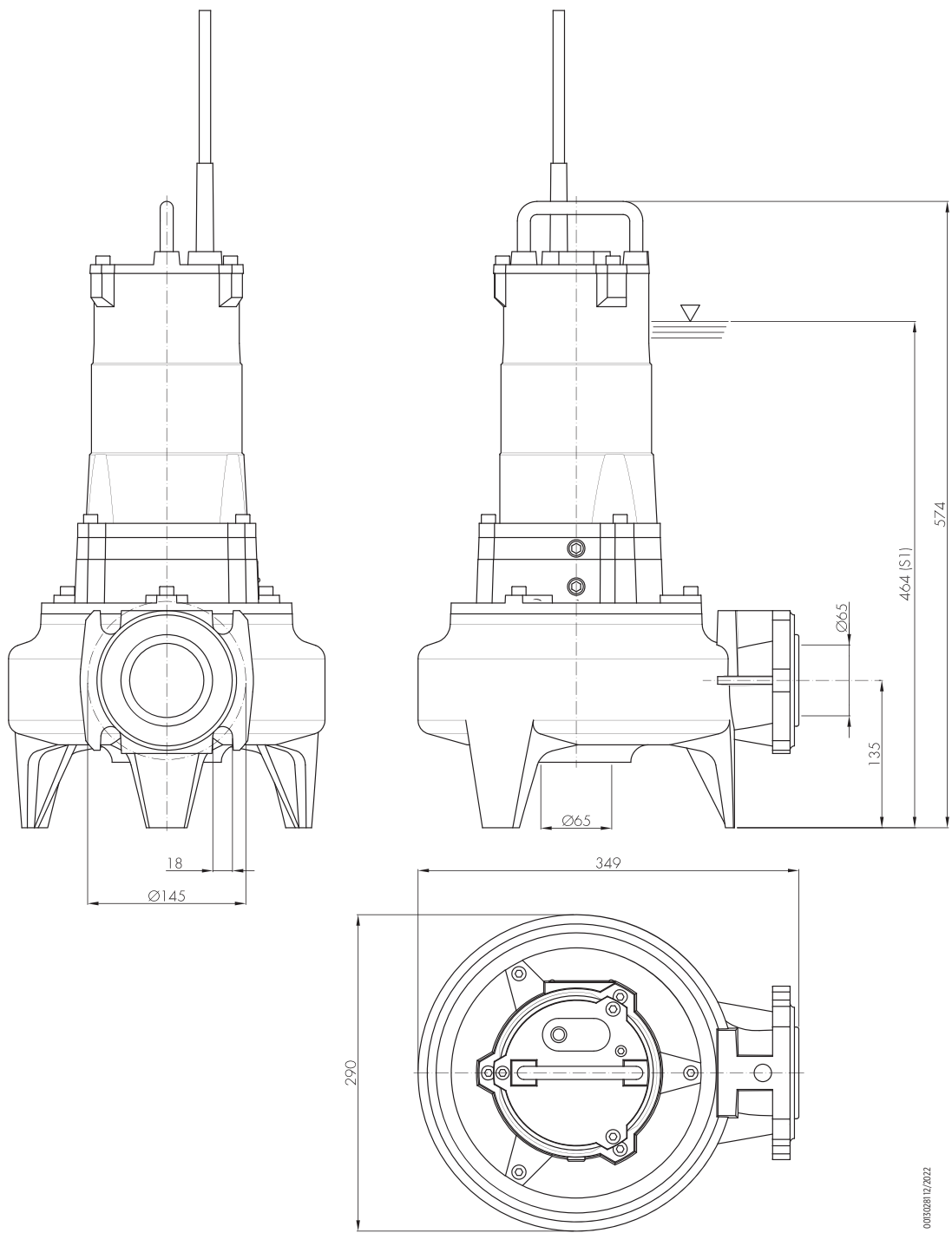

Packaging		
Pump model	Dimensions [mm]	Weight [kg]
65FWC-V-52-2,2	420x325x675	50

TECHNICAL DATA

Pump model	Motor absorbed power P ₁	Rated power P ₂		Voltage	Rated current	Phase	Power cable		float switch	Running capacitor	Delivery port	Weight [kg]
	[kW]	[kW]	[HP]	[V]	[A]		length [m]	Type		[µf]		
65FWC-V-52-2,2T	3,2	2,2	3	400	5,2	3 -	10	4G1,5	-	-	DN65	48

"-" = not available

• = available

HYDRAULIC PERFORMANCE AT 50 HZ

Pump model	Phase	Q = Delivery										
		l/sec 0	4	6	8	9	10	11	12	13	14	15
		m ³ /h 0	14,4	21,6	28,8	32,4	36	39,6	43,2	46,8	50,4	54
		US gpm 0	63,4	92,1	126,8	142,6	158,5	174,3	190,2	206	221,9	237,7
65FWC-V-52-2,2	3 -	16,5	12,5	10,2	9	8	6,8	6	5,3	3,7	2	1,5

HYDRAULIC PERFORMANCE AT 50 HZ

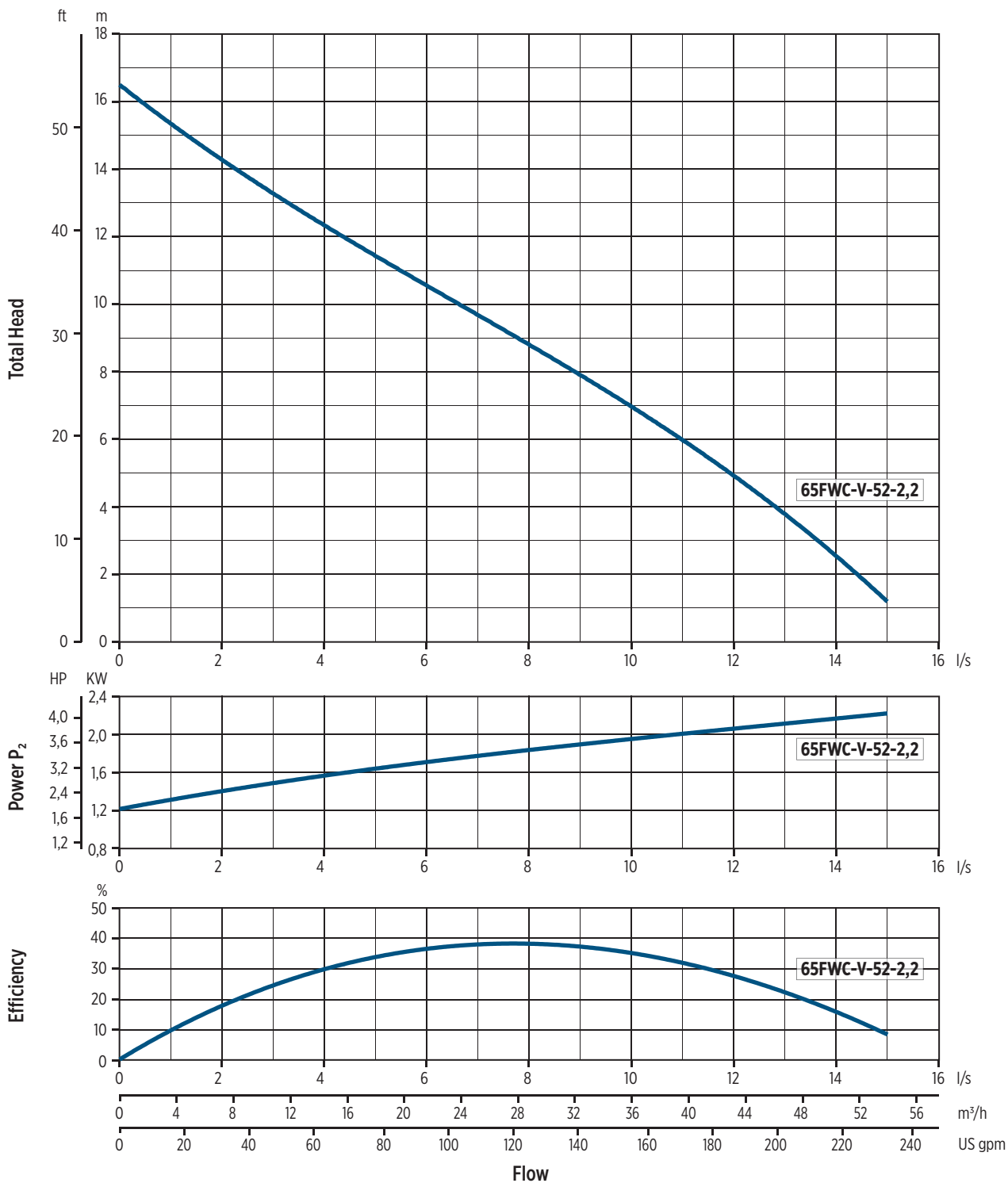

002009712/2022

INSTALLATION

INSTALLATION INSTRUCTIONS

PERMANENT INSTALLATION WITH COUPLING SYSTEM

It is the recommended installation for the permanent pumping station. The electric pump is guided by two pipes and it is connected automatically to the coupling system. The quick connection ensures that the pump can be easily removed and re-installed.

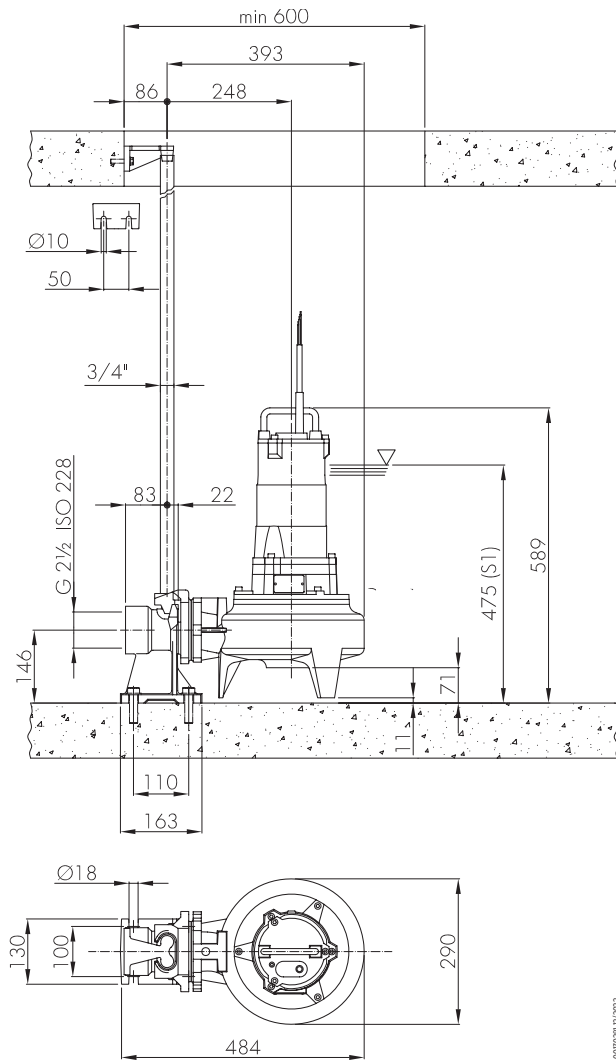

0101028 12/2022

TRANSPORTABLE INSTALLATION

Transportable as emergency pump with connection to the hose and for free installation in the well.

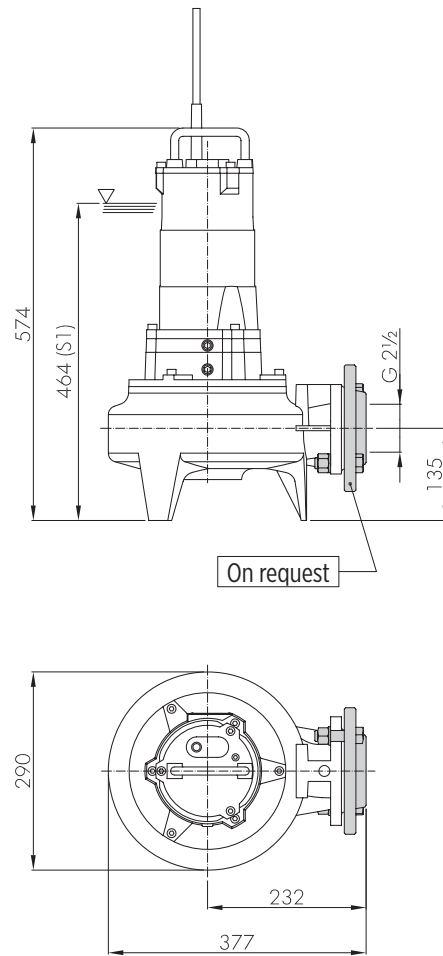

0101028 12/2022

65FWC M SERIES 50 HZ

FEATURES & BENEFITS

APPLICATIONS



Domestic / industrial grey water



Extraction of water from ponds, streams or pits and for rainwater collection



Wastewater



MARKETS



RESIDENTIAL



COMMERCIAL



INDUSTRY



AGRICULTURE

CAST IRON SUBMERSIBLE WASTEWATER LIFT PUMPS

Submersible electric pumps suitable for pumping screened waste water, draining the sewage of blocks of flats and houses and flooded premises in general.

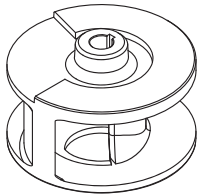

01030813/01/2022

SINGLE-CHANNEL IMPELLER

GENERAL FEATURES

		Materials/Constr.design
Single-channel impeller		Cast iron EN GJL200
External casing		Cast iron EN GJL200
Pump body		Cast iron EN GJL200
Cover		Cast iron EN GJL200
Mechanical seal	motor side	Seal ring
	pump side	Silicon carbide (SiC/SiC)
Motor shaft		Stainless steel AISI420
Power cable		10 m H07RN-F type, 4G1,5mm ²
		Motor
Constr.design		asynchronous squirrel cage-type oil filled
Type		2 poles; 50 Hz
Insulation class		F
Protection degree		IP68
Voltage	Three-phase	230V ±10%, 400V ±10%
		Limits of use
Maximum liquid temperature		+40 °C
pH of pumped liquid		6 - 10
Liquid density		1,0 kg/dm ³
Maximum immersion depth:		5 m
Min. immersion depth for continuous service		445 mm
Free passage		50 mm
Max. number of starting/hour		20
		Construction options

- 60 Hz version
- Different voltages
- Food-grade white oil

DIMENSIONAL DRAWINGS

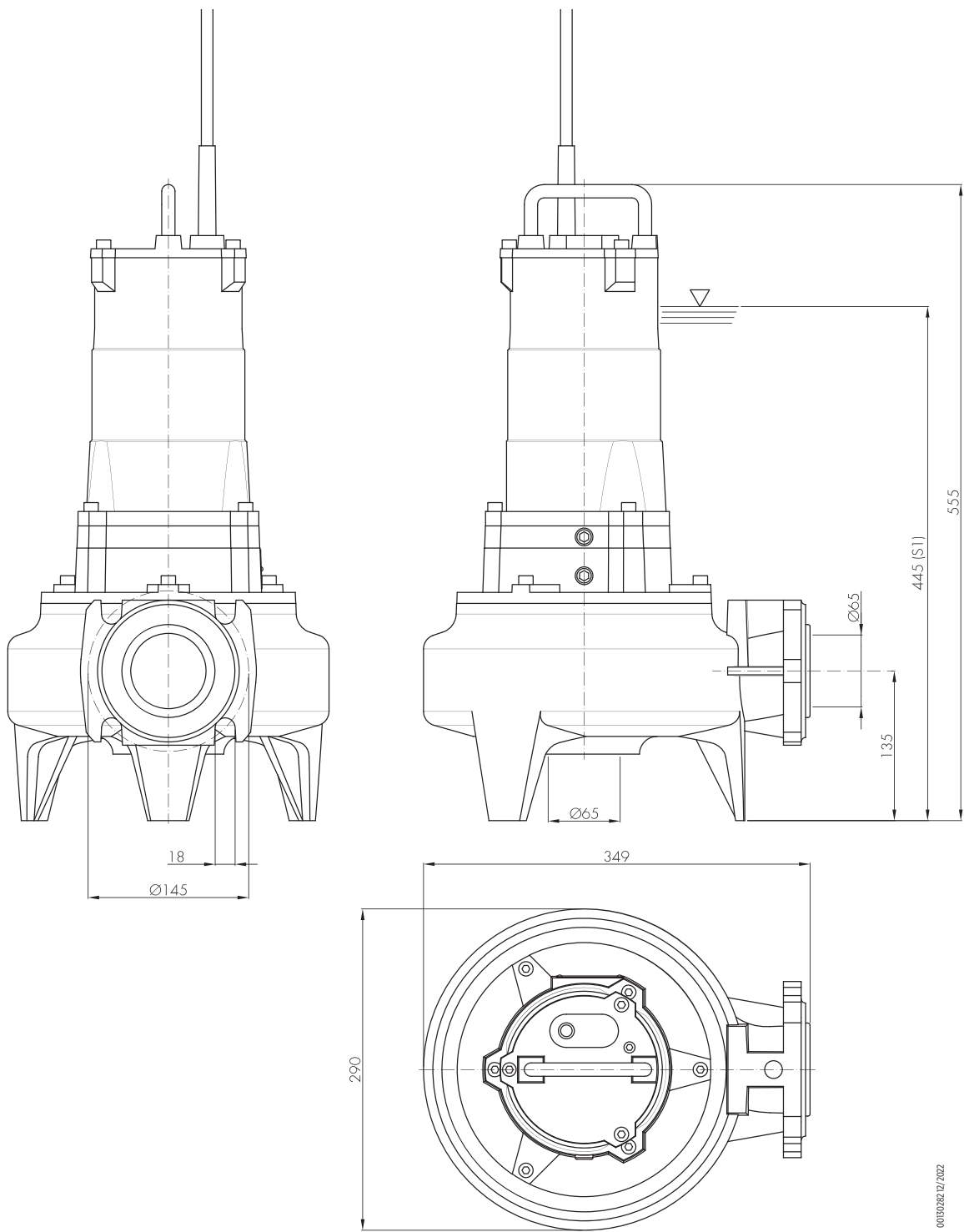

Packaging		
Pump model	Dimensions [mm]	Weight [kg]
65FWC-M-52-1,6T	420x325x675	52
65FWC-M-52-2,2T	420x325x675	52

TECHNICAL DATA

Pump model	Motor absorbed power P ₁	Rated power P ₂		Voltage	Rated current	Phase	Power cable		float switch	Running capacitor	Delivery port	Weight [kg]
	[kW]	[kW]	[HP]	[V]	[A]		length [m]	Type		[µf]		
65FWC-M-52-1,6T	2,5	1,6	2,1	400	4,4	3 -	10	4G1,5	-	-	DN65	50
65FWC-M-52-2,2T	3,2	2,2	3	400	5,2	3 -	10	4G1,5	-	-	DN65	50

"-" = not available
 • = available

HYDRAULIC PERFORMANCE AT 50 HZ

Pump model	Phase	Q = Delivery												
		l/sec 0	4	6	8	9	10	11	12	13	14	15	16	18
		m ³ /h 0	14,4	21,6	28,8	32,4	36	39,6	43,2	46,8	50,4	54	57,6	64,8
		US gpm 0	63,4	92,1	126,8	142,6	158,5	174,3	190,2	206	221,9	237,7	253,6	285,3
		H = Total meters head of water column [m]												
65FWC-M-52-1,6	3 -	18,5	12,5	10,4	8,5	7,7	6,8	5,7	4,9	3,6	2,3	1		
65FWC-M-52-2,2	3 -	24	17,8	15,3	13,2	12	11,3	10,2	9,1	7,9	6,6	5,1	3,6	1

HYDRAULIC PERFORMANCE AT 50 HZ

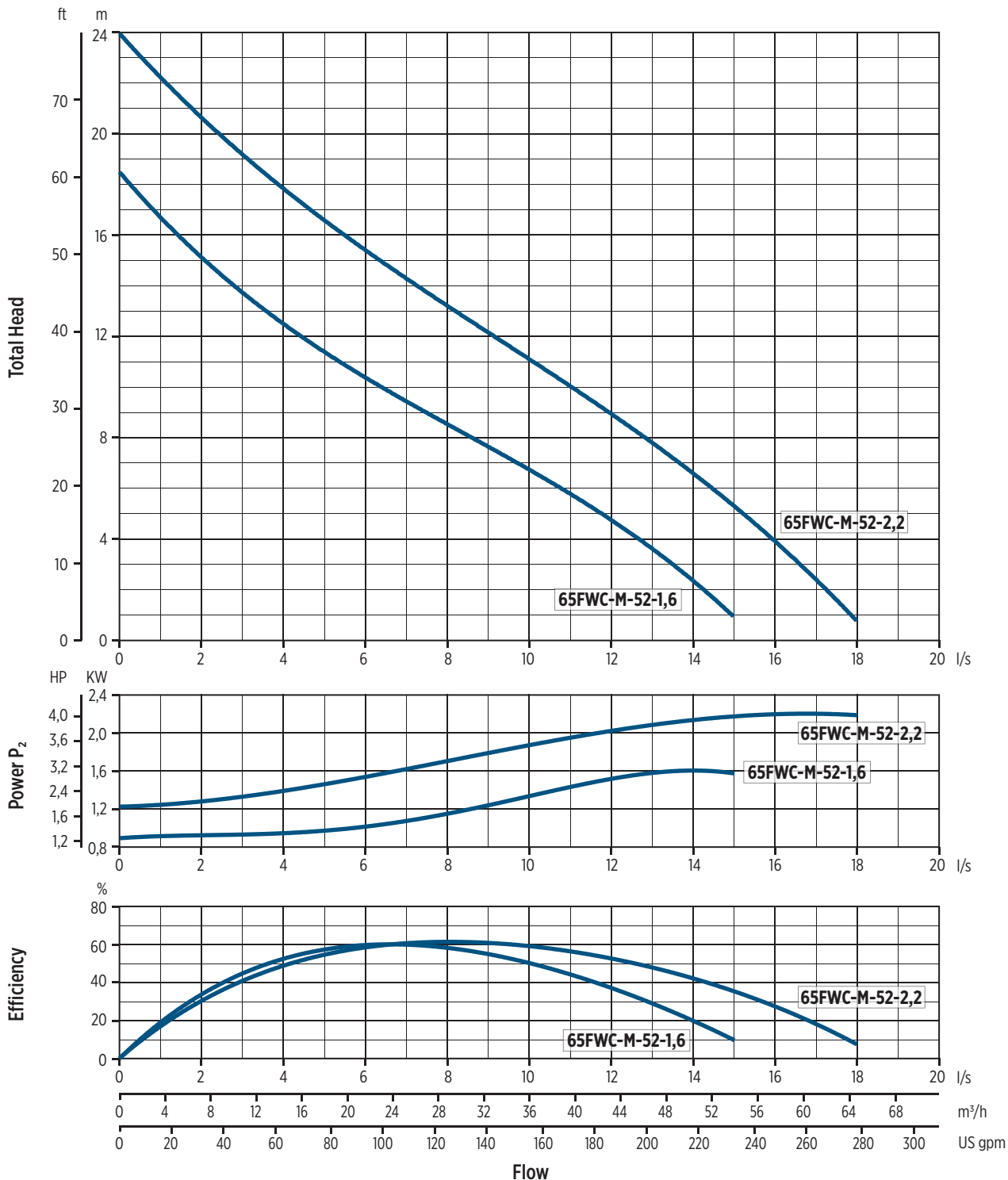

0010098 12/2022

65FWC V4 SERIES 50 HZ

FEATURES & BENEFITS

APPLICATIONS



Domestic / industrial grey water



Extraction of water from ponds, streams or pits and for rainwater collection



Wastewater



MARKETS



RESIDENTIAL



COMMERCIAL

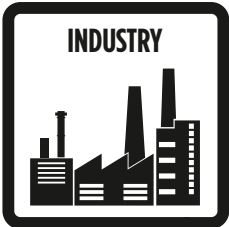

INDUSTRY



AGRICULTURE

CAST IRON SUBMERSIBLE WASTEWATER LIFT PUMPS

Submersible electric pumps particularly suitable for pumping industrial sewage, screened waste water and mud in the pumping stations. They can be used also to lift clear and dirty water and rain water.

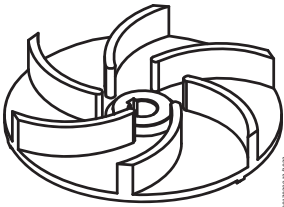

VORTEX IMPELLER

GENERAL FEATURES

		Materials/Constr.design
Vortex impeller		Cast iron EN GJL200
External casing		Cast iron EN GJL200
Pump body		Cast iron EN GJL200
Cover		Cast iron EN GJL200
Mechanical seal		Silicon carbide (SiC/SiC)
Motor shaft		Stainless steel AISI420
Power cable	Type	10 m H07RN-F type
	Single-phase	4G1,5mm ² , capacitor box and SCHUKO plug (CEE 7/VII)
	Three-phase	4G1,5mm ²
		Motor
Constr.design		asynchronous squirrel cage-type oil filled
Type		4 poles; 50 Hz
Insulation class		F
Protection degree		IP68
Voltage	Single-phase	230V ±6% built-in overheating protection
	Three-phase	230V ±10%, 400V ±10%
		Limits of use
Maximum liquid temperature		+40 °C
pH of pumped liquid		6 - 10
Liquid density		1,0 kg/dm ³
Maximum immersion depth:		5 m
Min. immersion depth for continuous service		442 mm
Free passage		60 mm
Max. number of starting/hour		20
		Construction options

- 60 Hz version
- Different voltages
- Food-grade white oil

DIMENSIONAL DRAWINGS

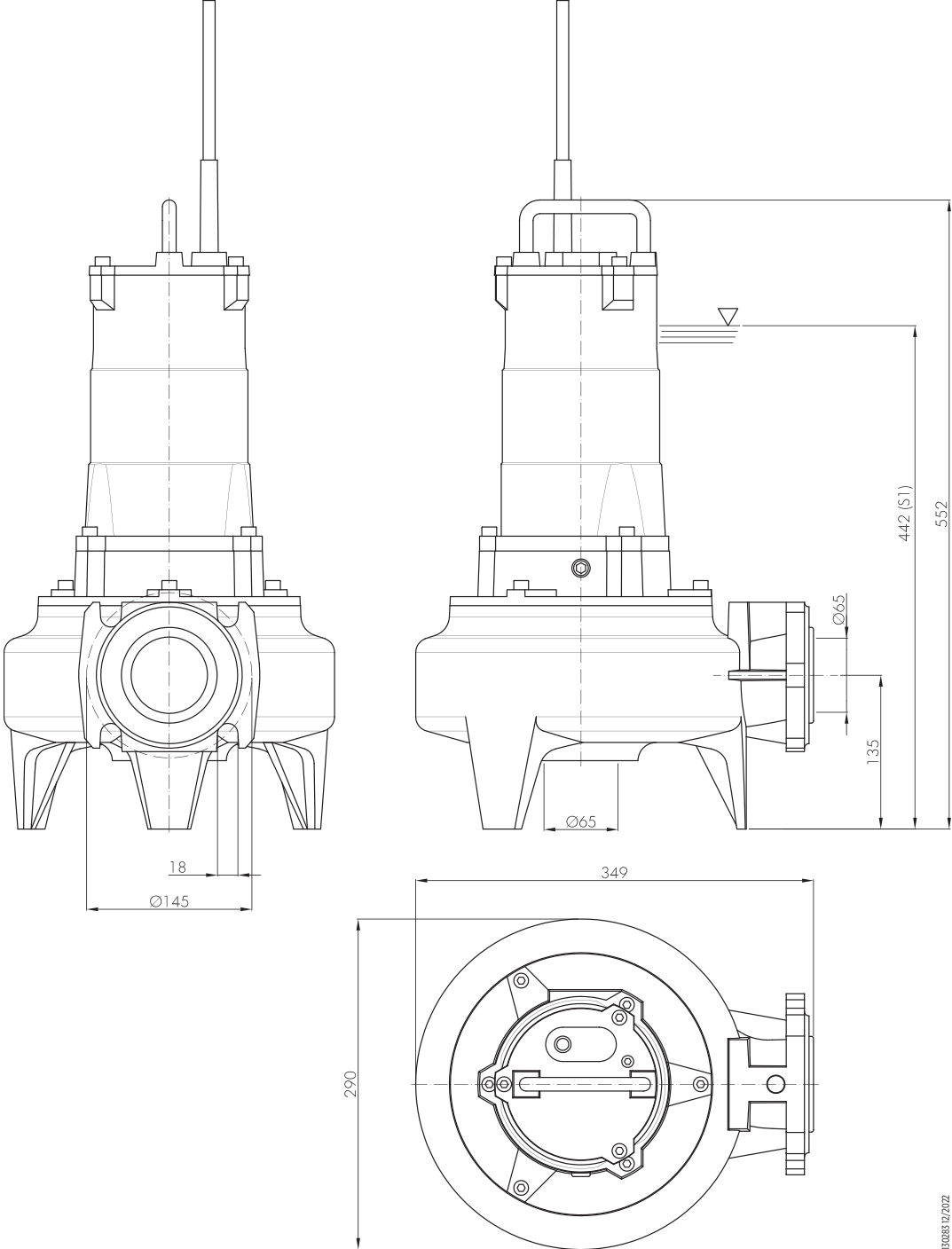

00130288 12/2012

Packaging		
Pump model	Dimensions [mm]	Weight [kg]
65FWC-V-54-0,75	420x325x675	40
65FWC-V-54-1,1	420x325x675	41
65FWC-V-54-1,6	420x325x675	42

TECHNICAL DATA

Pump model	Motor absorbed power P ₁	Rated power P ₂		Voltage	Rated current	Phase	Power cable		float switch	Running capacitor	Delivery port	Weight [kg]
	[kW]	[kW]	[HP]	[V]	[A]		length [m]	Type		[µf]		
65FWC-V-54-0,75M	1	0,75	1	230	5	1~	10	4G1,5	-	14	DN65	38
65FWC-V-54-0,75M-G	1	0,75	1	230	5	1~	10	4G1,5	•	14	DN65	38
65FWC-V-54-0,75T	1	0,75	1	400	1,9	3~	10	4G1,5	-	-	DN65	38
65FWC-V-54-0,75T-G	1	0,75	1	400	1,9	3~	10	4G1,5	•	-	DN65	38
65FWC-V-54-1,1M	1,5	1,1	1,5	230	7	1~	10	4G1,5	-	20	DN65	39
65FWC-V-54-1,1M-G	1,5	1,1	1,5	230	7	1~	10	4G1,5	•	20	DN65	39
65FWC-V-54-1,1T	1,5	1,1	1,5	400	2,8	3~	10	4G1,5	-	-	DN65	39
65FWC-V-54-1,1T-G	1,5	1,1	1,5	400	2,8	3~	10	4G1,5	•	-	DN65	39
65FWC-V-54-1,6T	2,5	1,6	2,1	400	4,4	3~	10	4G1,5	-	-	DN65	40

"-" = not available

• = available

HYDRAULIC PERFORMANCE AT 50 HZ

Pump model	Phase	Q = Delivery										
		l/sec 0	4	6	8	9	10	11	12	13	14	15
		m ³ /h 0	14,4	21,6	28,8	32,4	36	39,6	43,2	46,8	50,4	54
		US gpm 0	63,4	92,1	126,8	142,6	158,5	174,3	190,2	206	221,9	237,7
H = Total meters head of water column [m]												
65FWC-V-54-0,75	1~	6	4,7	3,8	3	2						
	3~	6	4,7	3,8	3	2						
65FWC-V-54-1,1	1~	8,2	7	6,1	5	4,3	3,7	3	2,2	1,2		
	3~	8,2	7	6,1	5	4,3	3,7	3	2,2	1,2		
65FWC-V-54-1,6	3~	11	9,5	8,5	7,2	6,6	6,1	5,9	5,4	4,9	4	2,8

HYDRAULIC PERFORMANCE AT 50 HZ

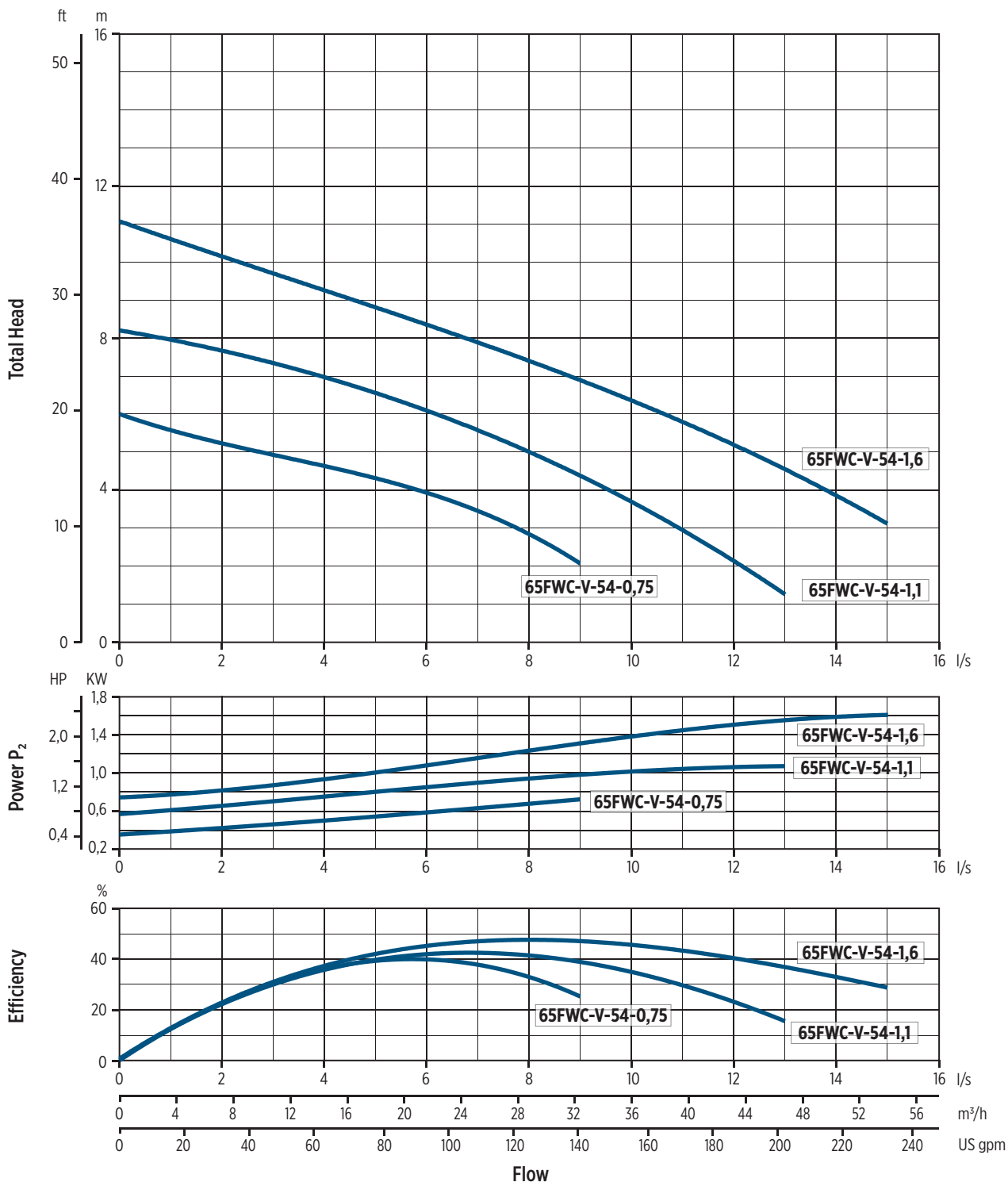

0020099.12/2022

INSTALLATION

INSTALLATION INSTRUCTIONS

PERMANENT INSTALLATION WITH COUPLING SYSTEM

It is the recommended installation for the permanent pumping station. The electric pump is guided by two pipes and it is connected automatically to the coupling system. The quick connection ensures that the pump can be easily removed and re-installed.

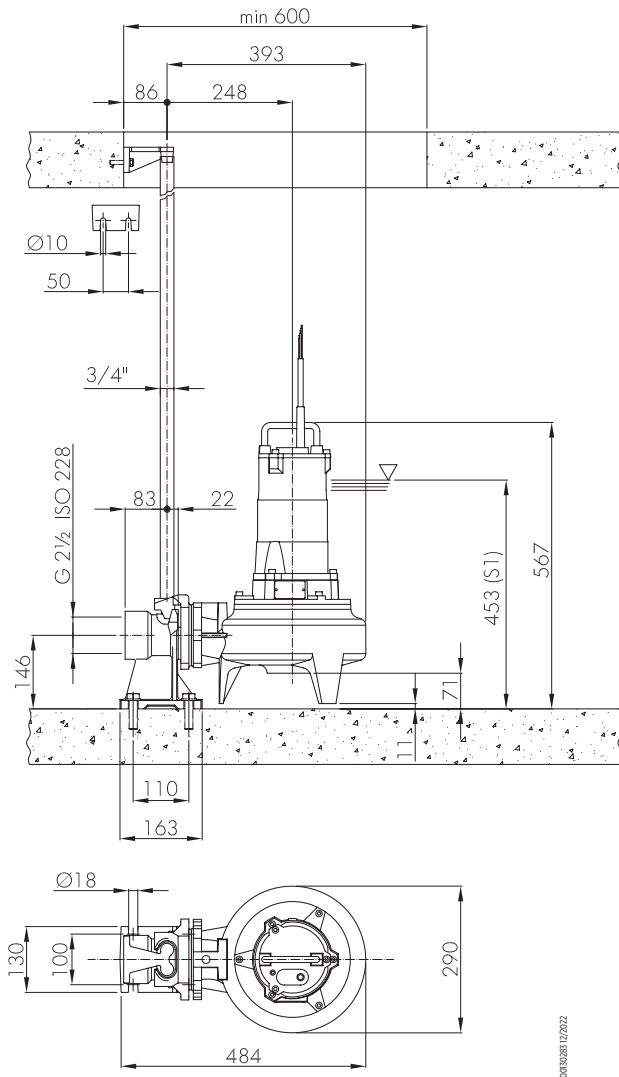

TRANSPORTABLE INSTALLATION

Transportable as emergency pump with connection to the hose and for free installation in the well.

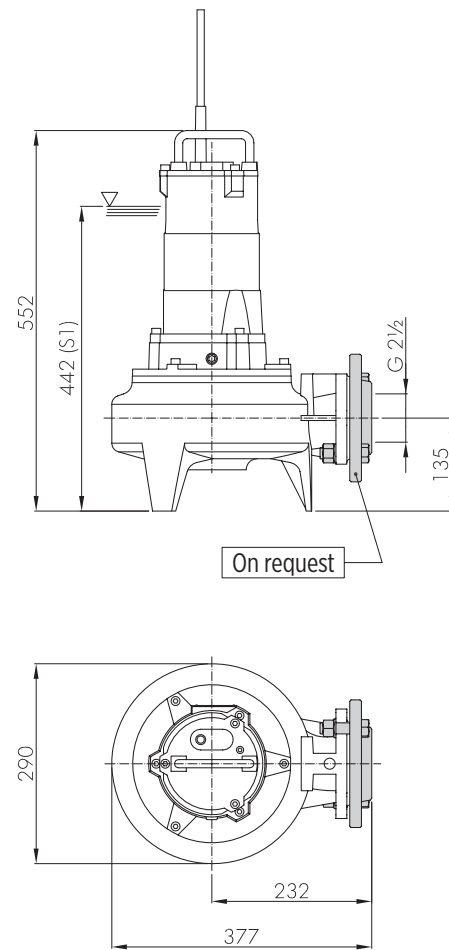

80FWC M4 SERIES 50 HZ

FEATURES & BENEFITS

APPLICATIONS



Domestic / industrial grey water



Extraction of water from ponds, streams or pits and for rainwater collection



Wastewater



MARKETS



CAST IRON SUBMERSIBLE WASTEWATER LIFT PUMPS

Submersible electric pumps particularly suitable for pumping industrial sewage, screened waste water and mud in the pumping stations. They can be used also to lift clear and dirty water and rain water.

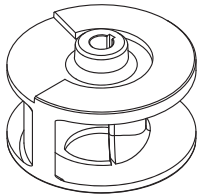

00000011/2022

SINGLE-CHANNEL IMPELLER

GENERAL FEATURES

		Materials/Constr.design
Single-channel impeller		Cast iron EN GJS400
External casing		Cast iron EN GJL250
Pump body		Cast iron EN GJL250
Cover		Cast iron EN GJL250
Mechanical seal	motor side	Graphite/Alumina
	pump side	Silicon carbide (SiC/SiC)
Motor shaft		Stainless steel AISI420
Power cable	Type	10 m SIRN8-F type
	80FWC-M-54-2,2T, 80FWC-M-54-3,1T	4G1,5+3x1mm ²
	80FWC-M-54-5,5T	4G2,5+3x1mm ²
		Motor
Constr.design		asynchronous squirrel cage-type in dry chamber
Type		4 poles; 50 Hz
Insulation class		F
Protection degree		IP68
Voltage	Three-phase	400V ±10%
Probe		Thermal in the winding
		Conductivity in the oil chamber
		Limits of use
Maximum liquid temperature		+40 °C
pH of pumped liquid		6 - 10
Liquid density		1,0 kg/dm ³
Maximum immersion depth:		5 m
Min. immersion depth for continuous service		517 mm
Free passage		80 mm
Max. number of starting/hour		20
		Construction options

- 60 Hz version
- Different voltages

DIMENSIONAL DRAWINGS

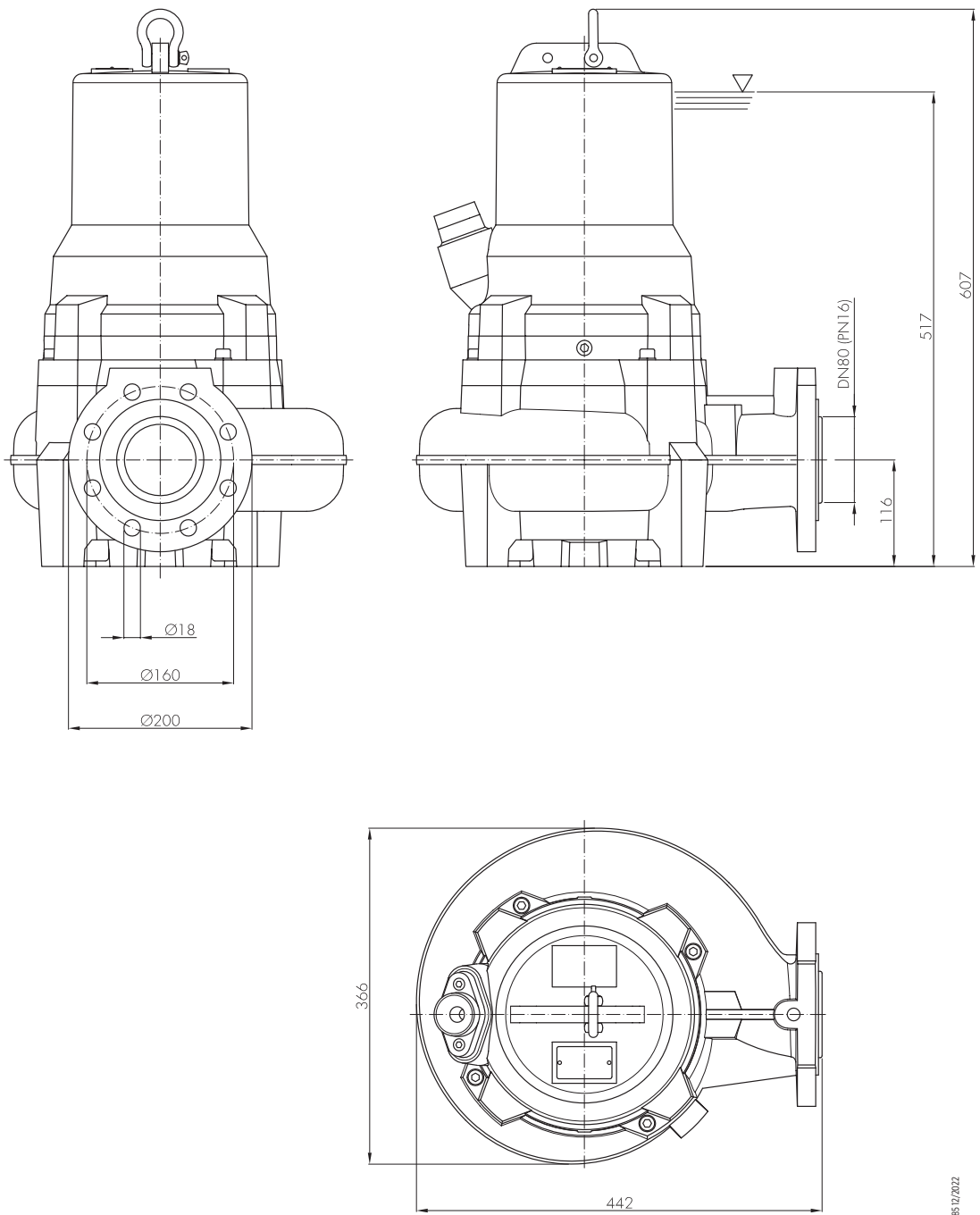

00180285 12/2022

Packaging		
Pump model	Dimensions [mm]	Weight [kg]
80FWC-M-54-2,2T	475x370x985	99
80FWC-M-54-3,1T	475x370x985	102
80FWC-M-54-5,5T	475x370x985	114

TECHNICAL DATA

Pump model	Motor absorbed power P ₁	Rated power P ₂		Voltage	Rated current	Phase	Power cable		float switch	Delivery port	Weight [kg]
	[kW]	[kW]	[HP]				[V]	[A]			
80FWC-M-54-2,2T	2,8	2,2	3	400	5,4	3 -	10	4G1,5+3x1	-	DN80	96
80FWC-M-54-3,1T	3,9	3,1	4,2	400	7,5	3 -	10	4G1,5+3x1	-	DN80	99
80FWC-M-54-5,5T	6,6	5,5	7,5	400	11,7	3 -	10	4G2,5+3x1	-	DN80	111

"-" = not available
 • = available

HYDRAULIC PERFORMANCE AT 50 HZ

Pump model	Phase	Q = Delivery												
		l/sec 0	6	10	15	20	25	30	35	38	40	42,8	45	47
		m ³ /h 0	21,6	36	54	72	90	108	126	136,8	144	154,1	162	169,2
		US gpm 0	92,1	158,5	237,7	317	396,2	475,5	554,8	602,3	634	678,4	713,3	745
		H = Total meters head of water column [m]												
80FWC-M-54-2,2T	3 -	10,8	8,8	7,6	6,4	5,3	3,7	2,4	2					
80FWC-M-54-3,1T	3 -	15,6	12,1	10,8	9,6	8,4	7,1	5,5	5,2	3,7	2			
80FWC-M-54-5,5T	3 -	19,8	16,6	15,1	13,6	12,4	11	9,6	9,2	7,9	6,6	5,2	3	2

HYDRAULIC PERFORMANCE AT 50 HZ

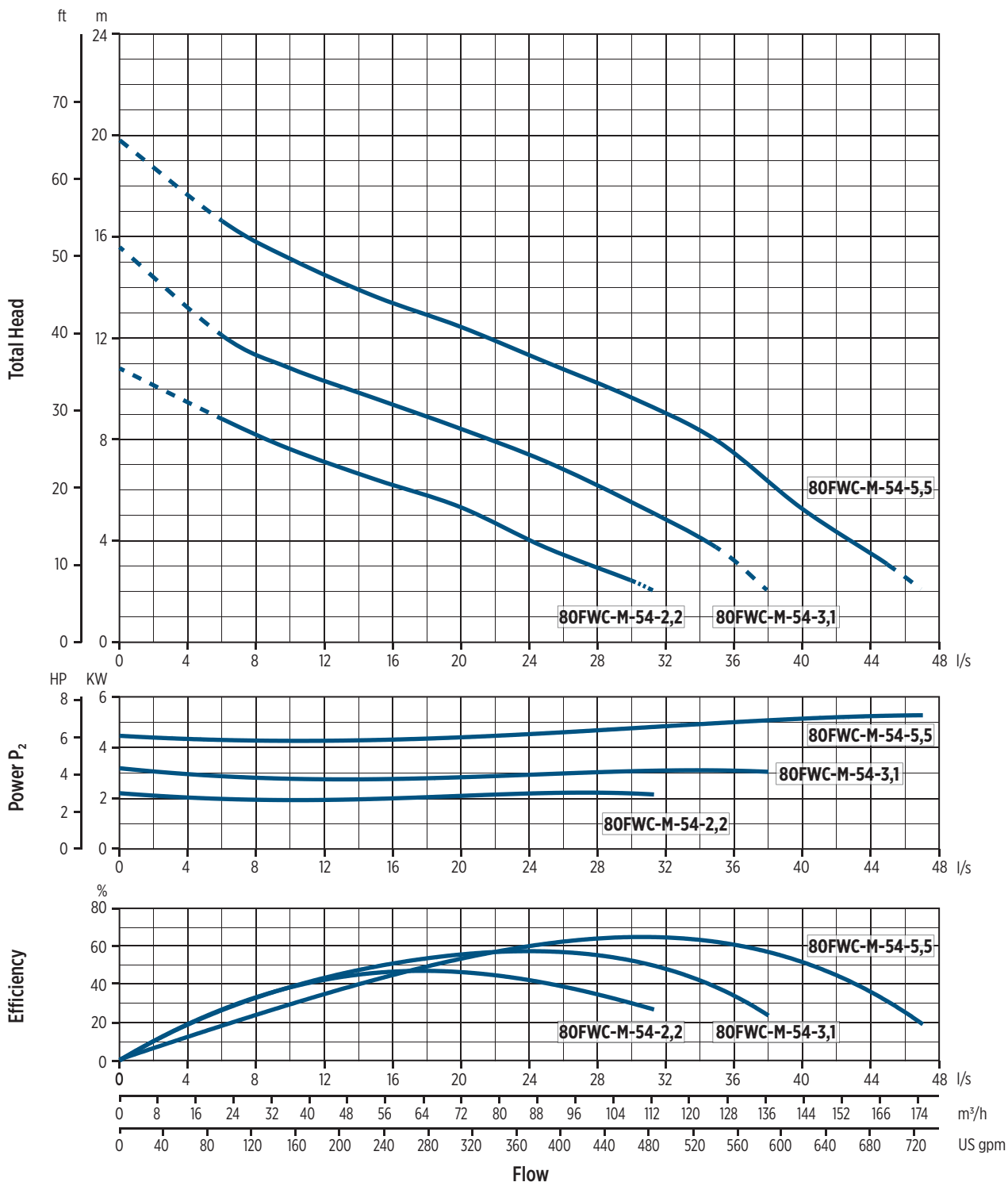

00201012/2022

INSTALLATION

INSTALLATION INSTRUCTIONS

PERMANENT INSTALLATION WITH COUPLING SYSTEM

It is the recommended installation for the permanent pumping station. The electric pump is guided by two pipes and it is connected automatically to the coupling system. The quick connection ensures that the pump can be easily removed and re-installed.

TRANSPORTABLE INSTALLATION

Transportable as emergency pump with connection to the hose and for free installation in the well.

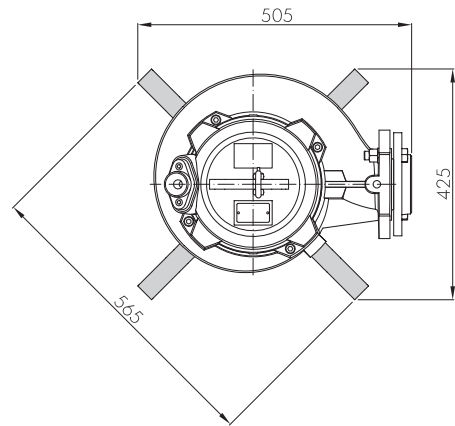
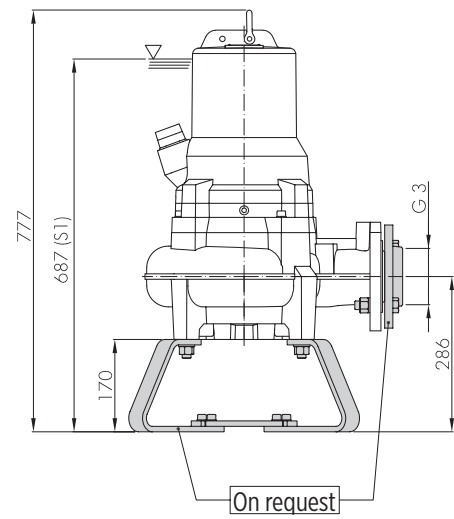
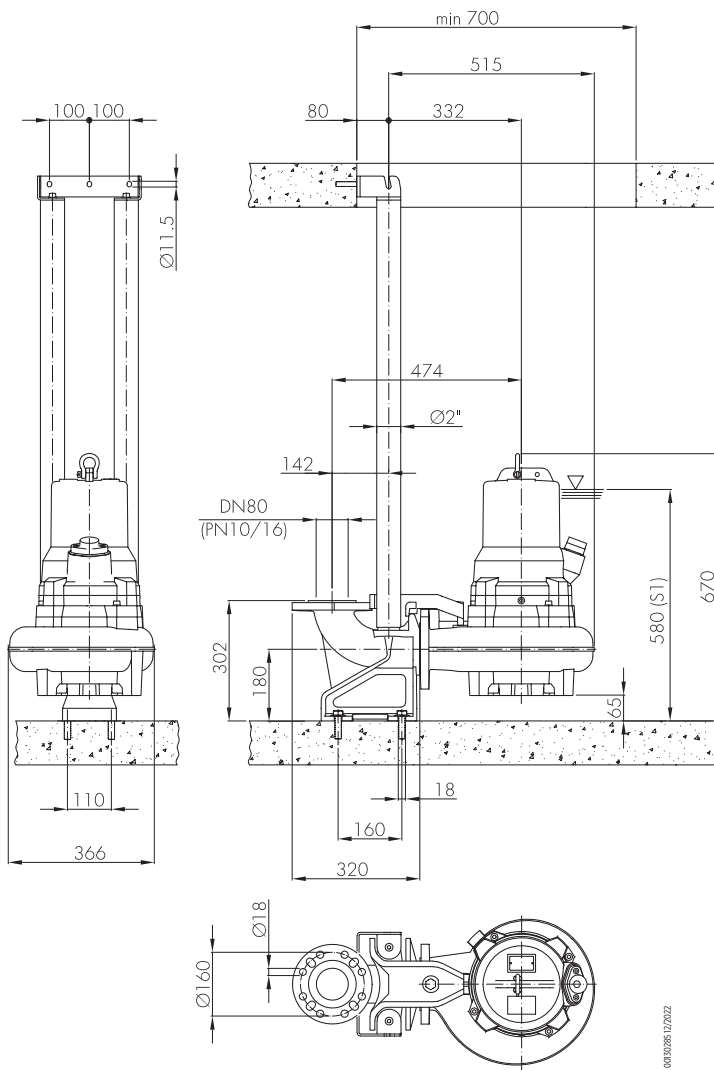

80FWC V4 SERIES 50 HZ

FEATURES & BENEFITS

APPLICATIONS



Domestic / industrial grey water



Extraction of water from ponds, streams or pits and for rainwater collection



Wastewater



For liquids with an high solid content or with filamentous particles



MARKETS



RESIDENTIAL



COMMERCIAL

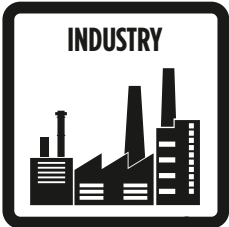

INDUSTRY



AGRICULTURE

CAST IRON SUBMERSIBLE WASTEWATER LIFT PUMPS

Submersible electric pumps particularly suitable for pumping industrial sewage, screened waste water and mud in the pumping stations. They can be used also to lift clear and dirty water and rain water.

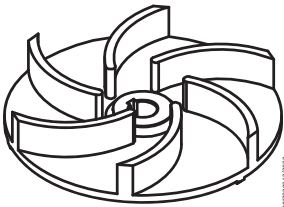

VORTEX IMPELLER

GENERAL FEATURES

Materials/Constr.design		
Vortex impeller	Cast iron EN GJL250	
External casing	Cast iron EN GJL250	
Pump body	Cast iron EN GJL250	
Cover	Cast iron EN GJL250	
Mechanical seal	motor side	Graphite/Alumina
	pump side	Silicon carbide (SiC/SiC)
Motor shaft	Stainless steel AISI420	
Power cable	Type	10 m SIRN8-F type
	80FWC-V-54-1,6T, 80FWC-V-54-2,2T, 80FWC-V-54-3,1T	4G1,5+3x1mm ²
	80FWC-V-54-5,5T	4G2,5+3x1mm ²
Motor		
Constr.design	asynchronous squirrel cage-type in dry chamber	
Type	4 poles; 50 Hz	
Insulation class	F	
Protection degree	IP68	
Voltage	Three-phase	400V ±10%
Probe		Thermal in the winding
		Conductivity in the oil chamber
Limits of use		
Maximum liquid temperature	+40 °C	
pH of pumped liquid	6 - 10	
Liquid density	1,0 kg/dm ³	
Maximum immersion depth:	5 m	
Min. immersion depth for continuous service	500 mm	
Free passage	80 mm	
Max. number of starting/hour	20	
Construction options		

- 60 Hz version
- Different voltages

DIMENSIONAL DRAWINGS

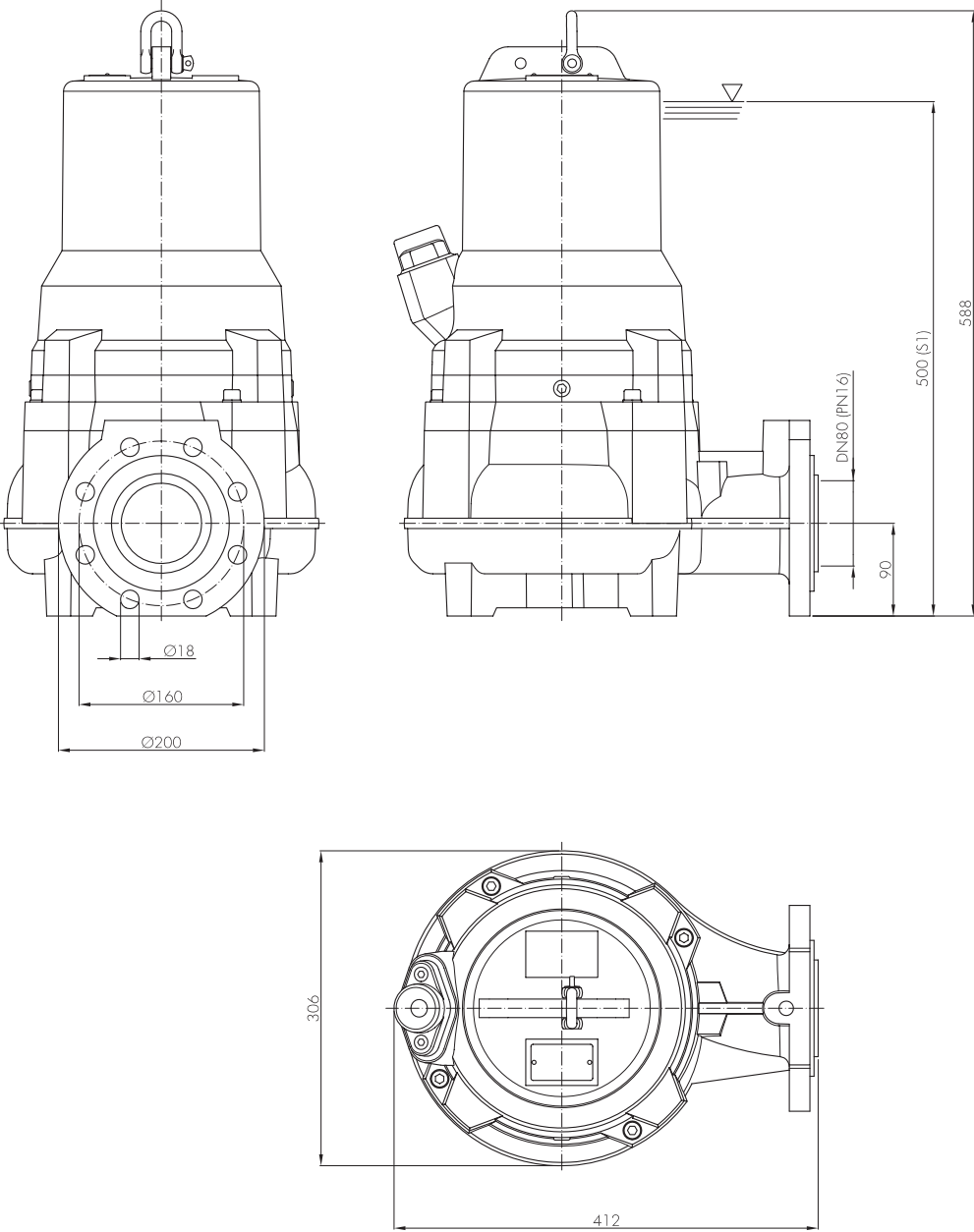

08/30/284/12/2022

Packaging		
Pump model	Dimensions [mm]	Weight [kg]
80FWC-V-54-1,6T	420x325x675	85
80FWC-V-54-2,2T	420x325x675	87
80FWC-V-54-3,1T	420x325x675	91
80FWC-V-54-5,5T	420x325x675	102

TECHNICAL DATA

Pump model	Motor absorbed power P ₁	Rated power P ₂		Voltage	Rated current	Phase	Power cable		float switch	Delivery port	Weight [kg]
	[kW]	[kW]	[HP]	[V]	[A]		length [m]	Type			
80FWC-V-54-1,6T	2,3	1,6	2,1	400	4,1	3 -	10	4G1,5+3x1	-	DN80	83
80FWC-V-54-2,2T	2,8	2,2	3	400	5,4	3 -	10	4G1,5+3x1	-	DN80	85
80FWC-V-54-3,1T	3,9	3,1	4,2	400	7,5	3 -	10	4G1,5+3x1	-	DN80	89
80FWC-V-54-5,5T	6,6	5,5	7,5	400	11,7	3 -	10	4G2,5+3x1	-	DN80	100

"-" = not available

• = available

HYDRAULIC PERFORMANCE AT 50 HZ

Pump model	Phase	Q = Delivery															
		l/sec 0	6	8	10	12	14	16	18	20	22	24	26	28	30	32	34
		m ³ /h 0	21,6	28,8	36	43,2	50,4	57,6	64,8	72	79,2	86,4	93,6	100,8	108	115,2	122,4
		US gpm 0	92,1	126,8	158,5	190,2	221,9	253,6	285,3	317	348,7	380,4	412,1	443,8	475,5	507,2	538,9
		H = Total meters head of water column [m]															
80FWC-V-54-1,6T	3 -	9	7,5	6,9	6,2	5,4	4,7		3,8	3	2,2						
80FWC-V-54-2,2T	3 -	10,5	8,8	8,3	7,6	6,9	6,3	5,5	4,7	3,7	2,7						
80FWC-V-54-3,1T	3 -	13	11,1	10,6	9,9	9,3	8,6	7,9	7,1	6,3	5,4	4,4	3,2	2			
80FWC-V-54-5,5T	3 -	16	14,1	13,6	12,8	12,3	11,7	11	10,3	9,5	8,7	7,8	6,9	5,8	4,8	3,5	2,3

HYDRAULIC PERFORMANCE AT 50 HZ

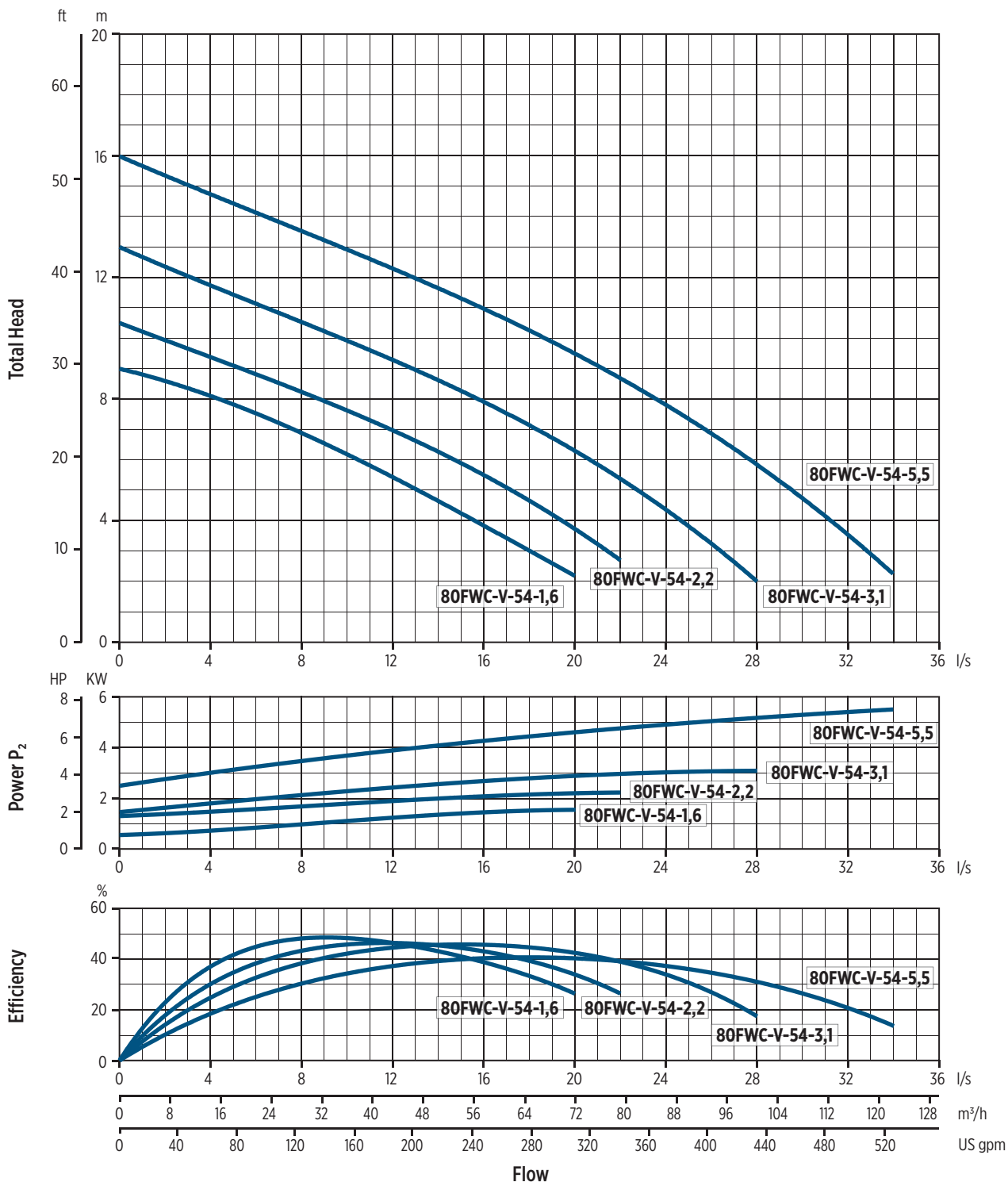

0020100.12/2022

INSTALLATION

INSTALLATION INSTRUCTIONS

PERMANENT INSTALLATION WITH COUPLING SYSTEM

It is the recommended installation for the permanent pumping station. The electric pump is guided by two pipes and it is connected automatically to the coupling system. The quick connection ensures that the pump can be easily removed and re-installed.

TRANSPORTABLE INSTALLATION

Transportable as emergency pump with connection to the hose and for free installation in the well.

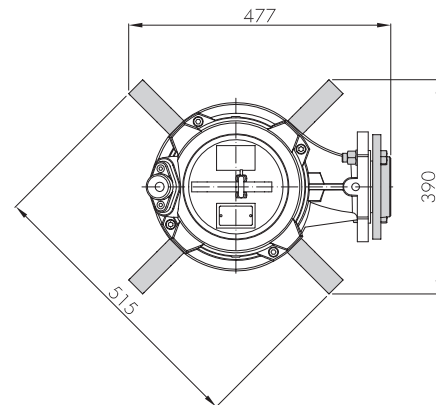
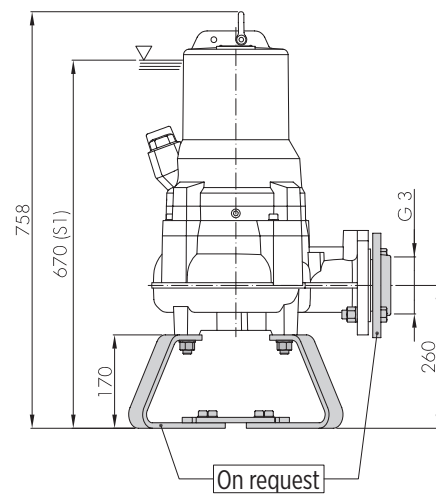
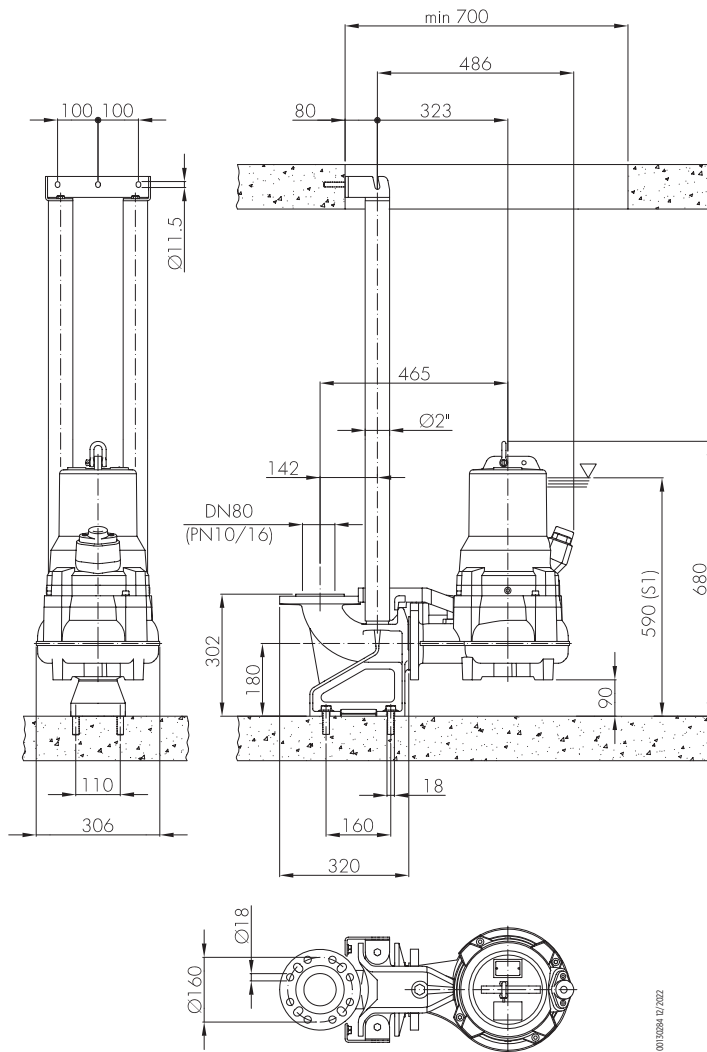

100FWC M4 SERIES 50 HZ

FEATURES & BENEFITS

APPLICATIONS



Domestic / industrial grey water



Extraction of water from ponds, streams or pits and for rainwater collection



Wastewater



MARKETS



RESIDENTIAL



COMMERCIAL



INDUSTRY



AGRICULTURE

CAST IRON SUBMERSIBLE WASTEWATER LIFT PUMPS

Submersible electric pumps particularly suitable for pumping industrial sewage, screened waste water and mud in the pumping stations. They can be used also to lift clear and dirty water and rain water.

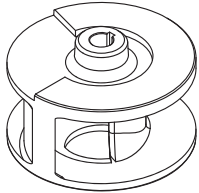

0010387 71/2002

SINGLE-CHANNEL IMPELLER

GENERAL FEATURES

		Materials/Constr.design
Single-channel impeller		Cast iron EN GJS400
External casing		Cast iron EN GJL250
Pump body		Cast iron EN GJL250
Cover		Cast iron EN GJL250
Mechanical seal	motor side	Graphite/Alumina
	pump side	Silicon carbide (SiC/SiC)
Motor shaft		Stainless steel AISI420
Power cable	Type	10 m SIRN8-F type
	100FWC-M-54-2,2T, 100FWC-M-54-3,1T	4G1,5+3x1mm ²
	100FWC-M-54-5,5T	4G2,5+3x1mm ²
		Motor
Constr.design		asynchronous squirrel cage-type in dry chamber
Type		4 poles; 50 Hz
Insulation class		F
Protection degree		IP68
Voltage	Three-phase	400V ±10%
Probe		Thermal in the winding
		Conductivity in the oil chamber
		Limits of use
Maximum liquid temperature		+40 °C
pH of pumped liquid		6 - 10
Liquid density		1,0 kg/dm ³
Maximum immersion depth:		5 m
Min. immersion depth for continuous service		517 mm
Free passage		80 mm
Max. number of starting/hour		20
		Construction options

- 60 Hz version
- Different voltages

DIMENSIONAL DRAWINGS

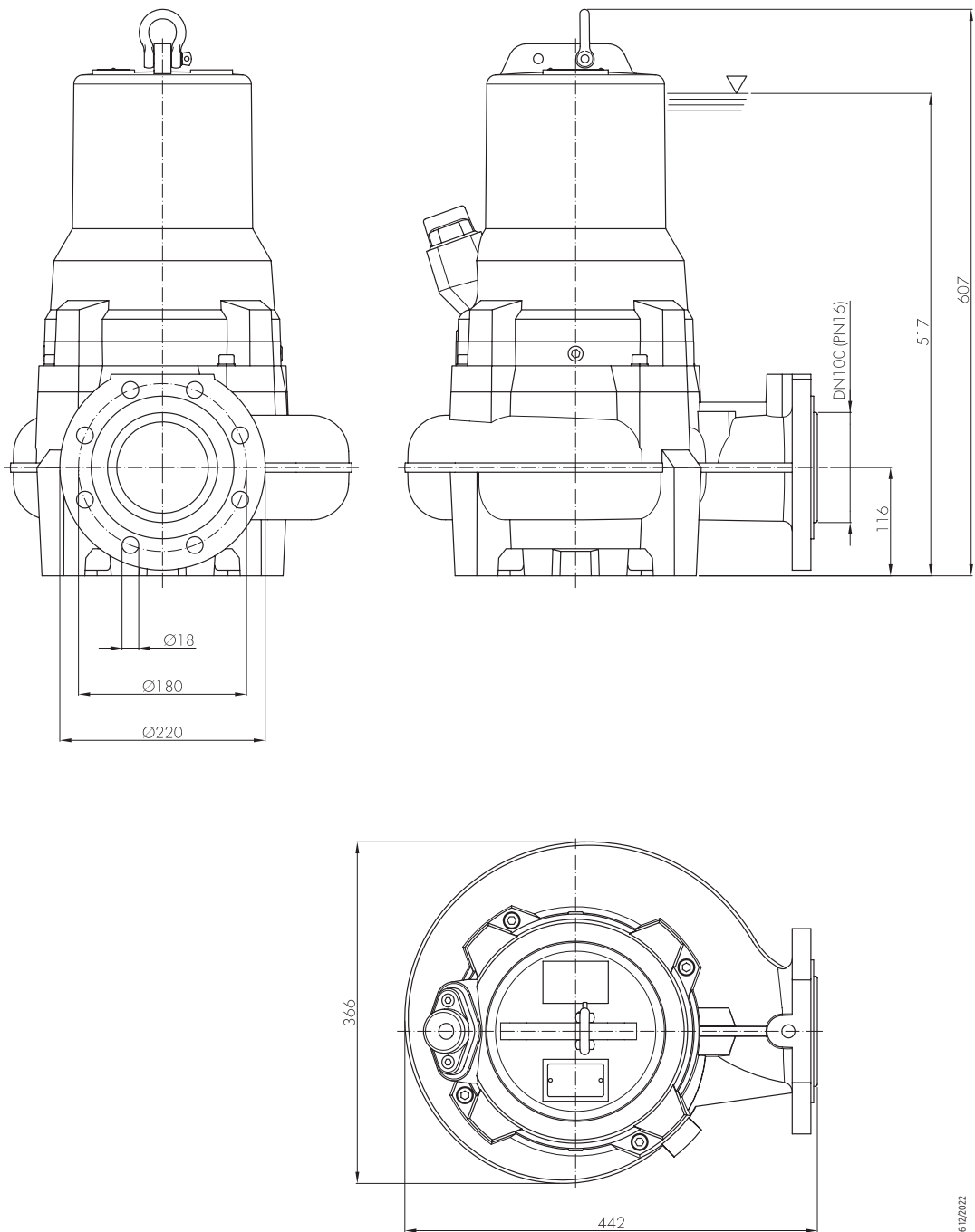

0030286 12/2022

Packaging		
Pump model	Dimensions [mm]	Weight [kg]
100FWC-M-54-2,2T	475x370x985	100
100FWC-M-54-3,1T	475x370x985	103
100FWC-M-54-5,5T	475x370x985	115

TECHNICAL DATA

Pump model	Motor absorbed power P ₁	Rated power P ₂		Voltage	Rated current	Phase	Power cable		float switch	Delivery port	Weight [kg]
	[kW]	[kW]	[HP]	[V]	[A]		length [m]	Type			
100FWC-M-54-2,2T	2,8	2,2	3	400	5,4	3 -	10	4G1,5+3x1	-	DN100	97
100FWC-M-54-3,1T	3,9	3,1	4,2	400	7,5	3 -	10	4G1,5+3x1	-	DN100	100
100FWC-M-54-5,5T	6,6	5,5	7,5	400	11,7	3 -	10	4G2,5+3x1	-	DN100	112

"-" = not available

• = available

HYDRAULIC PERFORMANCE AT 50 HZ

Pump model	Phase	Q = Delivery														
		l/sec 0	8	10	15	20	25	30	35	38	40	42,8	45	50	55	59
		m ³ /h 0	28,8	36	54	72	90	108	126	136,8	144	154,1	162	180	198	212,4
		US gpm 0	126,8	158,5	237,7	317	396,2	475,5	554,8	602,3	634	678,4	713,3	792,5	871,8	935,2
		H = Total meters head of water column [m]														
100FWC-M-54-2,2T	3 -	10,6	8,9	8,4	7,3	6,3	5,1	3,9	2,6	1,6						
100FWC-M-54-3,1T	3 -	12,7	11	10,5	9,4	8,4	7,2	6	4,5	3,6	3	2				
100FWC-M-54-5,5T	3 -	19	16	15,2	13,8	12,5	11,3	10,2	9,1	8,3	7,8	7,1	6,5	4,8	3	1,3

HYDRAULIC PERFORMANCE AT 50 HZ

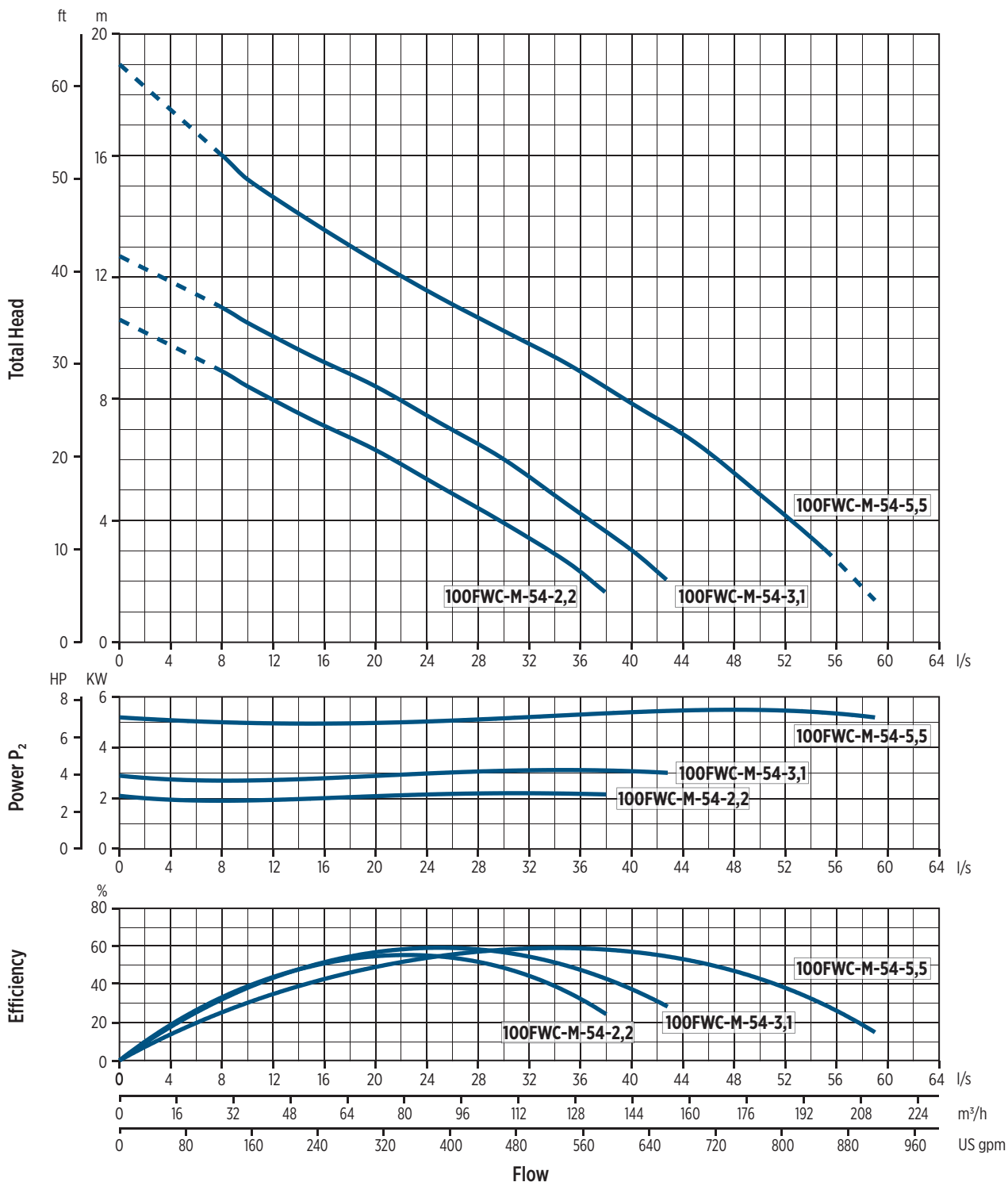

00201002 12/2022

INSTALLATION

INSTALLATION INSTRUCTIONS

PERMANENT INSTALLATION WITH COUPLING SYSTEM

It is the recommended installation for the permanent pumping station. The electric pump is guided by two pipes and it is connected automatically to the coupling system. The quick connection ensures that the pump can be easily removed and re-installed.

TRANSPORTABLE INSTALLATION

Transportable as emergency pump with connection to the hose and for free installation in the well.

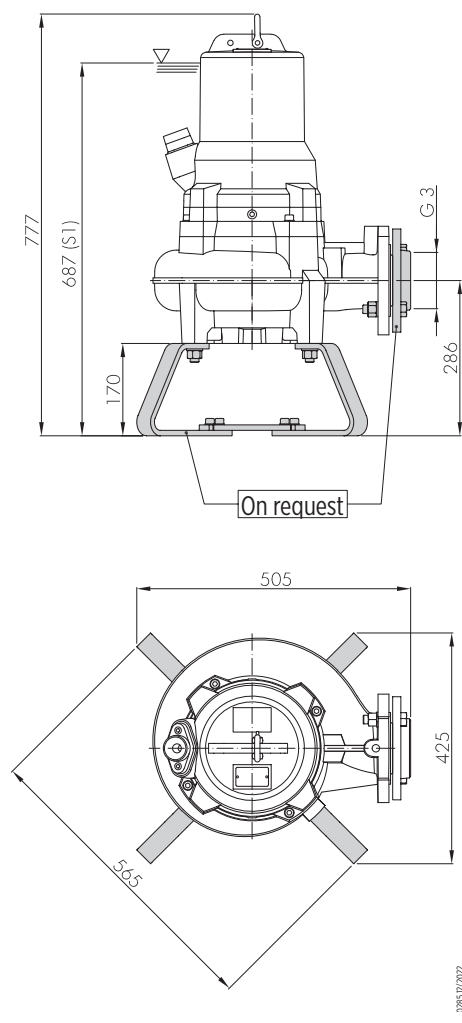
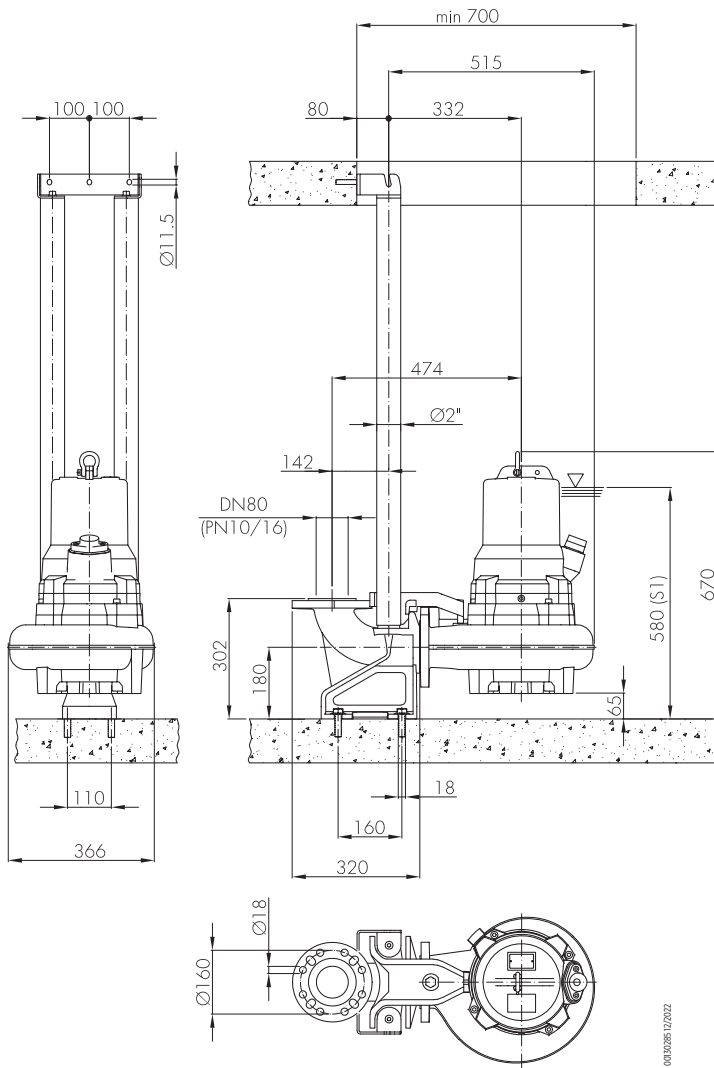

0050265/12/2022

328517/2022

FGR Series - Pumps with grinder unit 50 Hz



FGR SERIES - PUMPS WITH GRINDER UNIT 50 HZ

PUMP IDENTIFICATION CODE

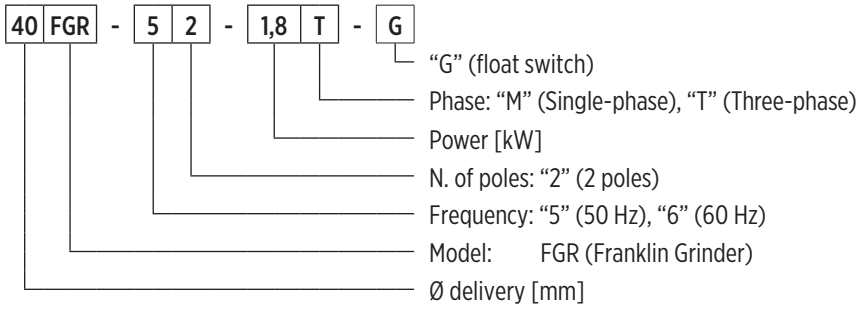

00140087 01/2023

40FGR SERIES 50 HZ

FEATURES & BENEFITS

APPLICATIONS



Pumping of clear non-loaded fluids



Extraction of water from ponds, streams or pits and for rainwater collection



Wastewater



MARKETS

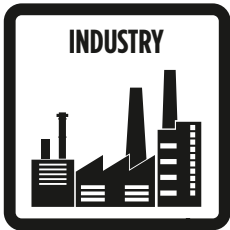

CAST IRON SUBMERSIBLE WASTEWATER LIFT PUMPS WITH GRINDER UNIT

These series of grinder pumps are particularly used in civil and industrial sewage plants. They have been designed to pump the liquid at high head with very low capacity. The cutter unit, in a special hard stainless steel, cuts into small pieces threadlike materials contained in the liquids. As the risk of clogging is avoided small diameter pipes are used. These pumps can be used to lift the sewage of blocks of flats and villas, small isolated areas far from the sewer systems; the sewage of hotels and campsites, in the food and paper industry and in those particular situations where the installation is often expensive by using a gravity system.

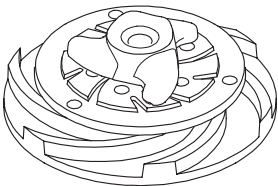

00102057 02/2021

IMPELLER WITH GRINDER UNIT

GENERAL FEATURES

Materials/Constr.design		
Impeller with grinder unit		Cast iron EN GJL200
External casing		Stainless steel AISI304
Pump body		Cast iron EN GJL200
Cover		Cast iron EN GJL200
Grinder unit		Hardened stainless steel
Mechanical seal	motor side	Seal ring
	pump side	Silicon carbide (SiC/SiC)
Motor shaft		Stainless steel AISI416
Power cable	Type	10 m H07RN-F type
	Single-phase	4G1mm ² with SHUKO plug (CEE7/VII), box with manual overload cut-out and with starting and operating capacitors.
	Three-phase	4G1mm ²
Motor		
Constr.design		asynchronous squirrel cage-type in dry chamber
Type		2 poles; 50 Hz
Insulation class		F
Protection degree		IP68
Voltage	Single-phase	230V ±6% built-in overheating protection, float switch as optional
	Three-phase	230V ±10%, 400V ±10%
Limits of use		
Maximum liquid temperature		+40 °C
pH of pumped liquid		6 - 10
Liquid density		1,0 kg/dm ³
Maximum immersion depth:		5 m
Min. immersion depth for continuous service		303 mm
Max. number of starting/hour		20
Construction options		

- 60 Hz version
- Different voltages
- Food-grade white oil

DIMENSIONAL DRAWINGS

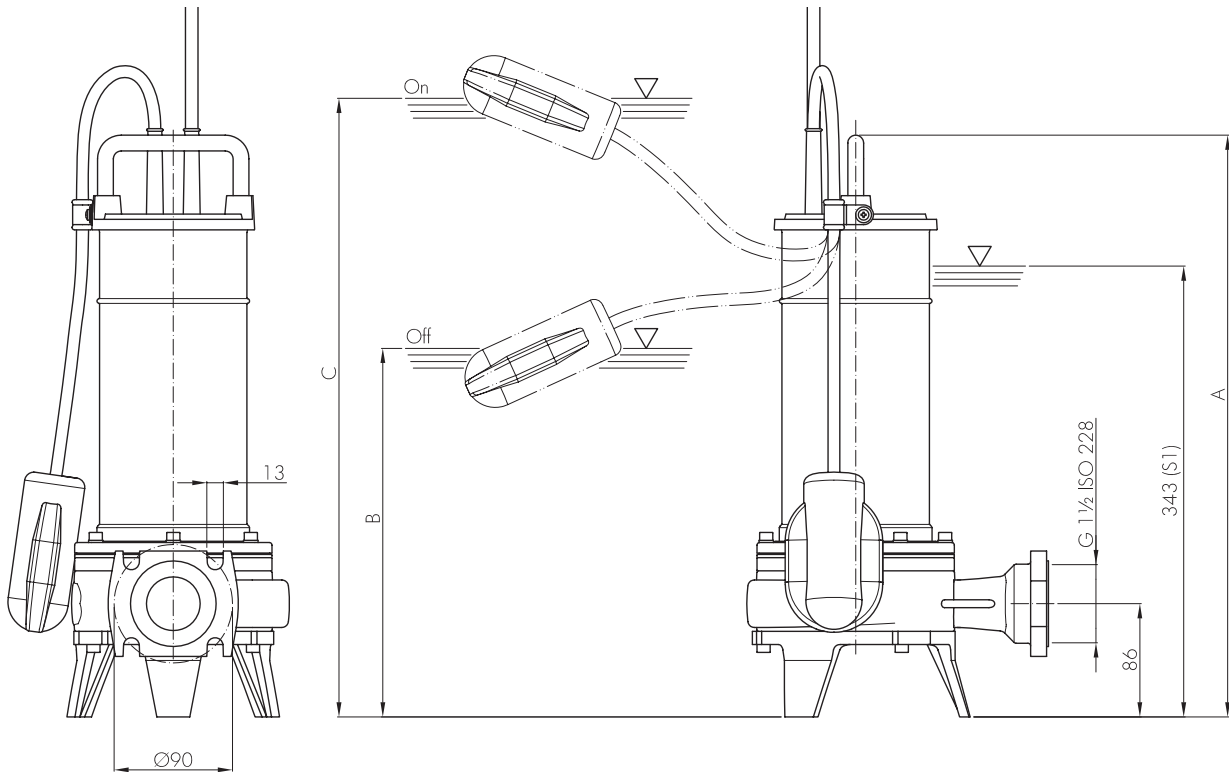

Dimensions [mm]			
Pump model	A	B	C
40FGR-52-0,75	438	280	470
40FGR-52-1,1	463	305	495

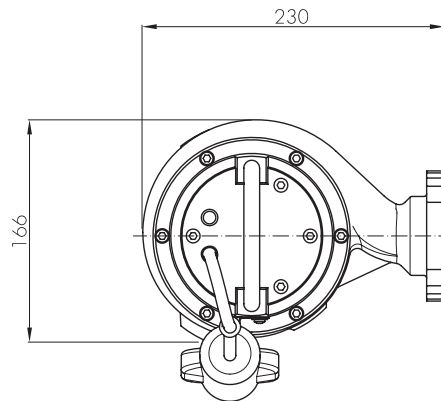

0050291.02/2023

Packaging		
Pump model	Dimensions [mm]	Weight [kg]
40FGR-52-0,75	255x205x560	18,7
40FGR-52-1,1	255x205x560	20,7

Pallet			
Pump model	Dimensions [mm]	N° of pumps	Weight [kg]
40FGR-52-0,75	800x1200x900	32	600
40FGR-52-1,1	800x1200x900	32	670

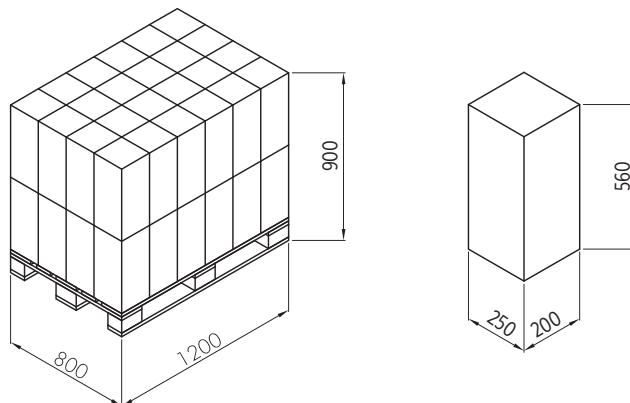

00130292.02/2023

TECHNICAL DATA

Pump model	Motor absorbed power P ₁	Rated power P ₂		Voltage	Rated current	Phase	Power cable		float switch	Running capacitor	Delivery port	Weight [kg]
	[kW]	[kW]	[HP]	[V]	[A]		length [m]	Type		[μf]		
40FGR-52-0,75M	0,9	0,75	1	230	4,8	1 ~	10	4G1	-	20	G1½	18
40FGR-52-0,75M-G	0,9	0,75	1	230	4,8	1 ~	10	4G1	•	20	G1½	18
40FGR-52-0,75T	0,9	0,75	1	400	1,8	3 ~	10	4G1	-	-	G1½	18
40FGR-52-1,1M	1,4	1,1	1,5	230	6	1 ~	10	4G1	-	25	G1½	20
40FGR-52-1,1M-G	1,4	1,1	1,5	230	6	1 ~	10	4G1	•	25	G1½	20
40FGR-52-1,1T	1,4	1,1	1,5	400	2,1	3 ~	10	4G1	-	-	G1½	20

"-" = not available

• = available

HYDRAULIC PERFORMANCE AT 50 HZ

Pump model	Phase	Q = Delivery							
		l/sec 0	0,5	1	1,5	2	2,5	3	3,5
		m ³ /h 0	1,8	3,6	5,4	7,2	9	10,8	12,6
		US gpm 0	7,9	15,8	23,7	31,7	39,6	47,5	55,5
		H = Total meters head of water column [m]							
40FGR-52-0,75	1 ~	18,5	17,4	16,2	14	11,6	8,5	1,3	
	3 ~	18,5	17,4	16,2	14	11,6	8,5	1,3	
40FGR-52-1,1	1 ~	21	19,7	18,5	16,6	14,2	11,2	7,8	1
	3 ~	21	19,7	18,5	16,6	14,2	11,2	7,8	1

PERFORMANCE CURVES AT 50 HZ

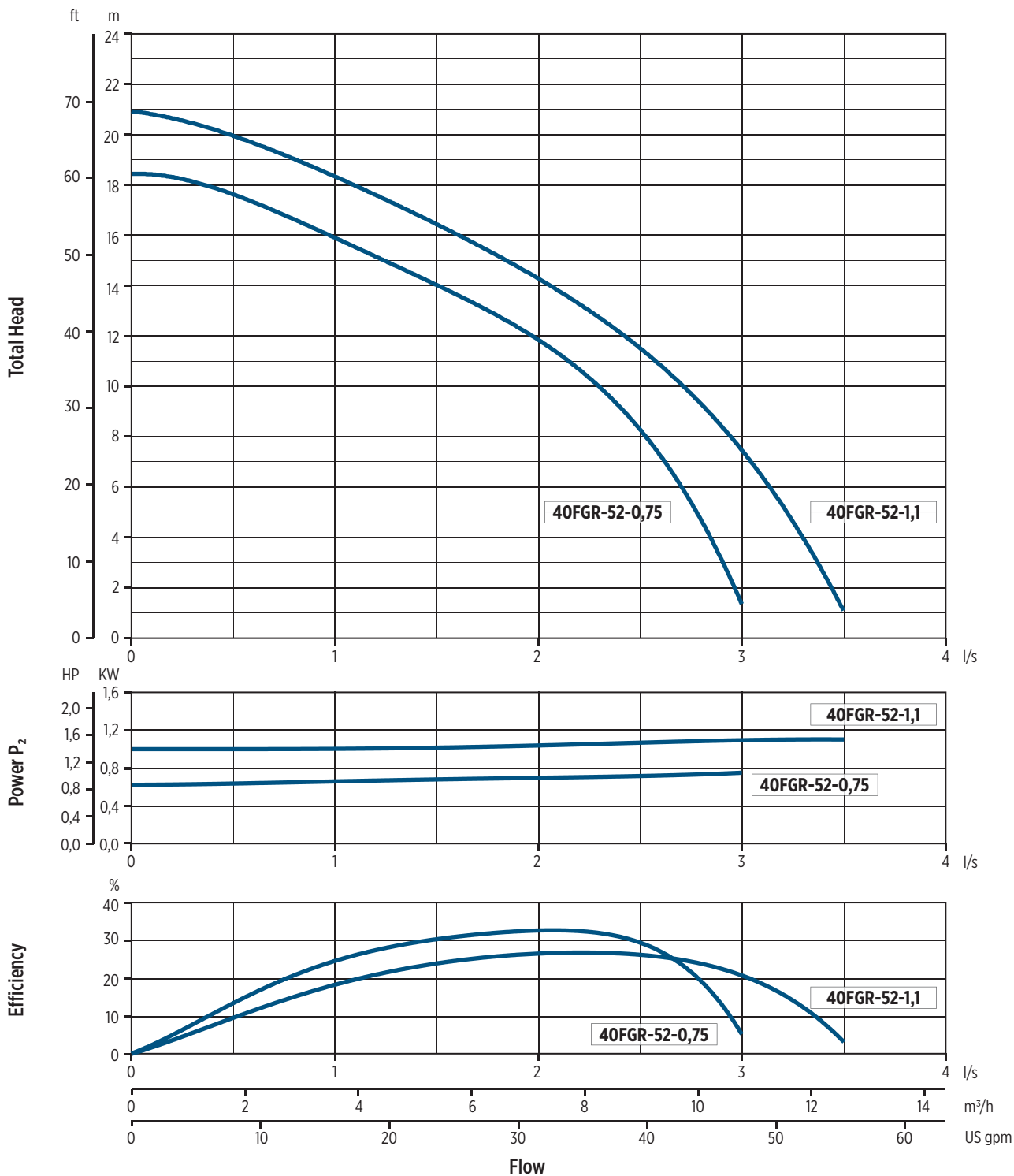

00202005 02/2023

INSTALLATION

INSTALLATION INSTRUCTIONS

PERMANENT INSTALLATION WITH COUPLING SYSTEM

It is the recommended installation for the permanent pumping station. The electric pump is guided by two pipes and it is connected automatically to the coupling system. The quick connection ensures that the pump can be easily removed and re-installed.

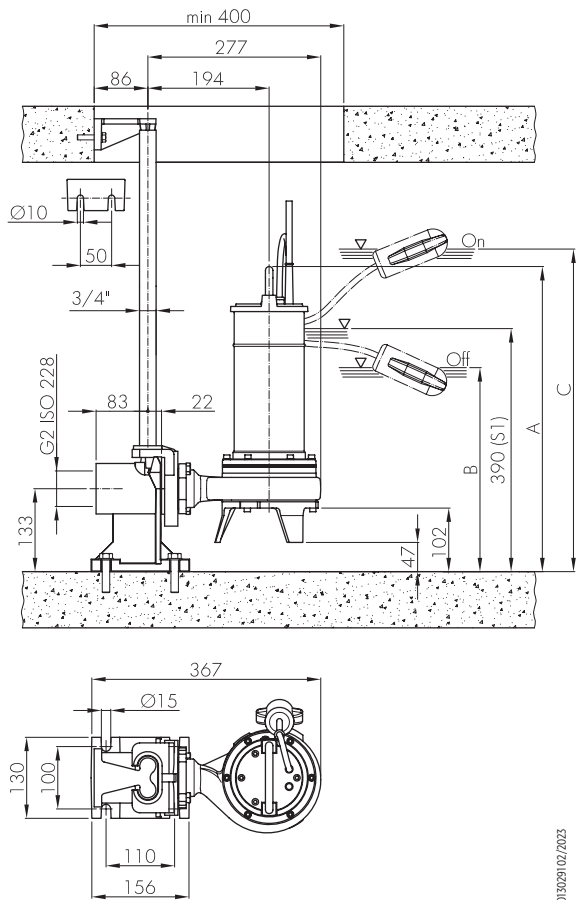

00130291 02/2023

TRANSPORTABLE INSTALLATION

Transportable as emergency pump with connection to the hose and for free installation in the well.

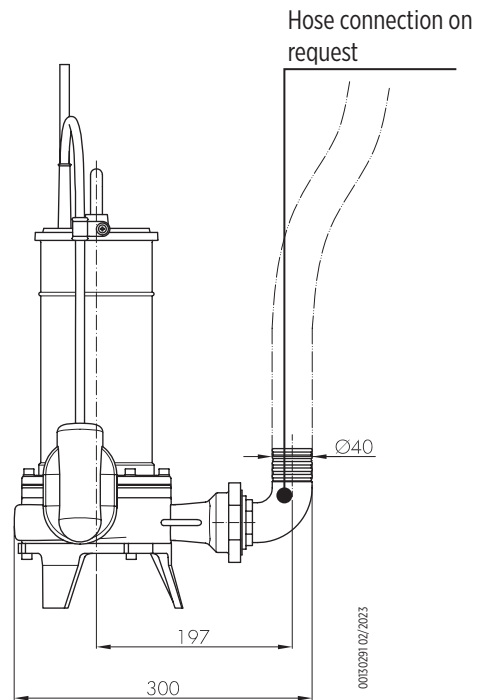

Pump model	Installation Dimensions [mm]		
	A	B	C
40FGR-52-0,75	485	330	515
40FGR-52-1,1	510	355	540

50FGR SERIES 50 HZ

FEATURES & BENEFITS

APPLICATIONS



Pumping of clear non-loaded fluids



Extraction of water from ponds, streams or pits and for rainwater collection



Wastewater



MARKETS



CAST IRON SUBMERSIBLE WASTEWATER LIFT PUMPS WITH GRINDER UNIT

These series of grinder pumps are particularly used in civil and industrial sewage plants. They have been designed to pump the liquid at high head with very low capacity. The cutter unit, in a special hard stainless steel, cuts into small pieces threadlike materials contained in the liquids. As the risk of clogging is avoided small diameter pipes are used. These pumps can be used to lift the sewage of blocks of flats and villas, small isolated areas far from the sewer systems; the sewage of hotels and campsites, in the food and paper industry and in those particular situations where the installation is often expensive by using a gravity system.

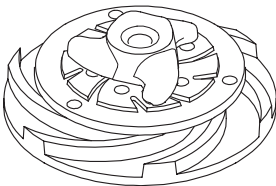

00102567 02/2021

IMPELLER WITH GRINDER UNIT

GENERAL FEATURES

Materials/Constr.design		
Impeller with grinder unit		Cast iron EN GJL200
External casing		Cast iron EN GJL200
Pump body		Cast iron EN GJL200
Cover		Cast iron EN GJL200
Grinder unit		Stainless steel AISI431
Mechanical seal	motor side	Graphite/Alumina
	pump side	Silicon carbide (SiC/SiC)
Motor shaft		Stainless steel AISI431
Power cable	Type	10 m H07RN-F type
	Single-phase	4G1mm ² with SHUKO plug (CEE7/VII), box with manual overload cut-out and with starting and operating capacitors.
	Single-phase 50FGR-52-1,6M	4G2,5mm ² with SHUKO plug (CEE7/VII), box with manual overload cut-out and with starting and operating capacitors.
	Three-phase	4G1,5mm ²
Motor		
Constr.design		asynchronous squirrel cage-type oil filled
Type		2 poles; 50 Hz
Insulation class		F
Protection degree		IP68
Voltage	Single-phase	230V ±6% built-in overheating protection (up to 1,1 kW), float switch as optional
	Three-phase	230V ±10%, 400V ±10%
Limits of use		
Maximum liquid temperature		+40 °C
pH of pumped liquid		6 - 10
Liquid density		1,0 kg/dm ³
Maximum immersion depth:		5 m
Min. immersion depth for continuous service		
50FGR-52-1,1M/T		373 mm
50FGR-52-1,6M/T / 50FGR-52-2,2T		440 mm
Max. number of starting/hour		20
Construction options		

- 60 Hz version
- Different voltages
- Food-grade white oil

DIMENSIONAL DRAWINGS

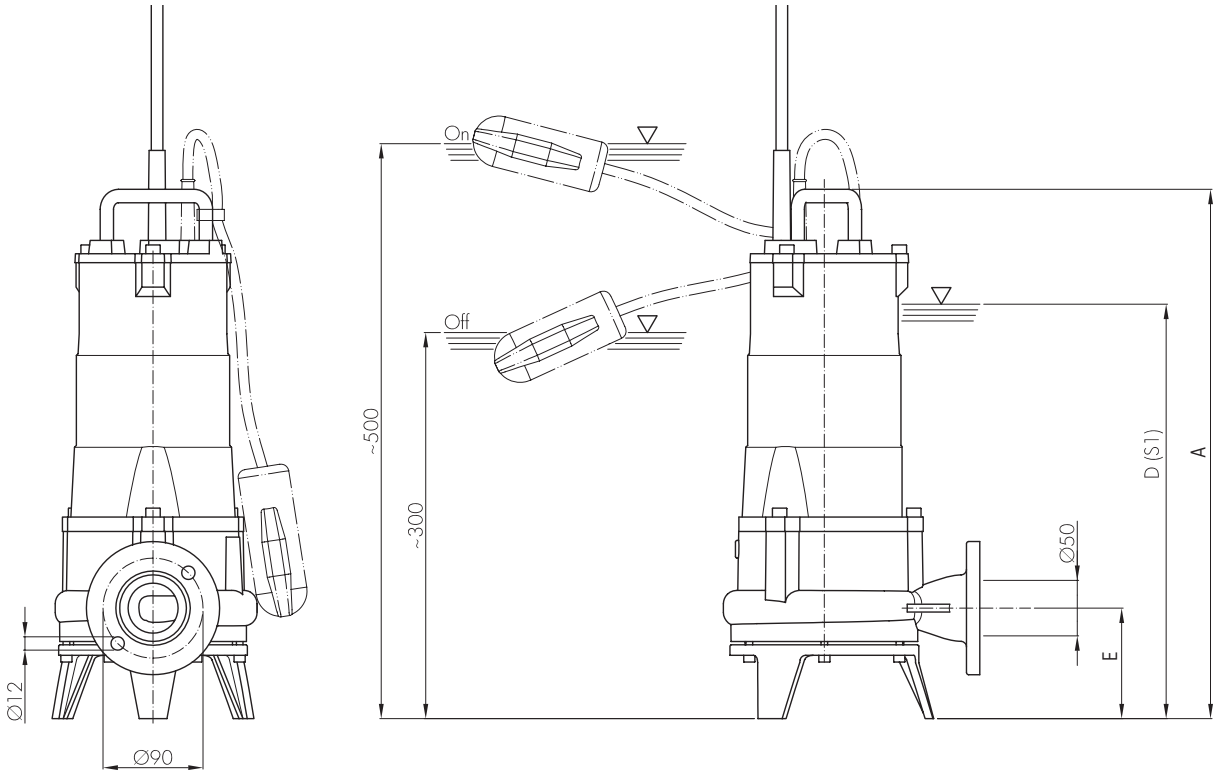

Pump model	Dimensions [mm]				
	A	D	E	F	G
50FGR-52-1,1	477	373	100	185	231
50FGR-52-1,6	550	440	110	220	276
50FGR-52-2,2	550	440	110	220	276

Packaging		
Pump model	Dimensions [mm]	Weight [kg]
50FGR-52-1,1	290x245x585	35
50FGR-52-1,6	300x260x585	41
50FGR-52-2,2	300x260x585	43

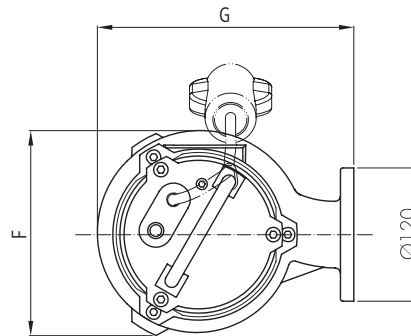

00150294 02/2023

TECHNICAL DATA

Pump model	Motor absorbed power P ₁	Rated power P ₂		Voltage	Rated current	Phase	Power cable		float switch	Running capacitor	Delivery port	Weight [kg]
	[kW]	[kW]	[HP]	[V]	[A]		length [m]	Type		[μf]		
50FGR-52-1,1M	1,4	1,1	1,5	230	7	1 ~	10	4G1,5	-	30	G2 (Ø50)	34
50FGR-52-1,1M-G	1,4	1,1	1,5	230	7	1 ~	10	4G1,5	•	30	G2 (Ø50)	34
50FGR-52-1,1T	1,4	1,1	1,5	230	11	1 ~	10	4G2,5	•	-	G2 (Ø50)	34
50FGR-52-1,1T-G	1,4	1,1	1,5	230	11	1 ~	10	4G2,5	-	-	G2 (Ø50)	34
50FGR-52-1,6M	2,3	1,6	2,1	400	3	3 ~	10	4G1,5	-	40	G2 (Ø50)	40
50FGR-52-1,6M-G	2,3	1,6	2,1	400	3	3 ~	10	4G1,5	•	40	G2 (Ø50)	40
50FGR-52-1,6T	2,3	1,6	2,1	400	4	3 ~	10	4G1,5	-	-	G2 (Ø50)	40
50FGR-52-1,6T-G	2,3	1,6	2,1	400	4	3 ~	10	4G1,5	•	-	G2 (Ø50)	40
50FGR-52-2,2T	3,1	2,2	3	400	5	3 ~	10	4G1,5	-	-	G2 (Ø50)	42

"-" = not available

• = available

HYDRAULIC PERFORMANCE AT 50 HZ

Pump model	Phase	Q = Delivery										
		l/sec 0	0,5	1	1,5	2	2,5	3	3,5	4	4,5	5
		m ³ /h 0	1,8	3,6	5,4	7,2	9	10,8	12,6	14,4	16,2	18
		US gpm 0	7,9	15,8	23,7	31,7	39,6	47,5	55,5	63,4	71,3	79,2
H = Total meters head of water column [m]												
50FGR-52-1,1	1 ~	21	19	17	15,8	14	12	9,5	8,8	7,8	5,8	2
	3 ~	21	19	17	15,8	14	12	9,5	8,8	7,8	5,8	2
50FGR-52-1,6	1 ~	27	25	21	20,5	19	18	15,5	14,5	13	10	5
	3 ~	27	25	21	20,5	19	18	15,5	14,5	13	10	5
50FGR-52-2,2	3 ~	34	32	29,5	27,5	25,7	23,8	22	20	17,5	15	10

PERFORMANCE CURVES AT 50 HZ

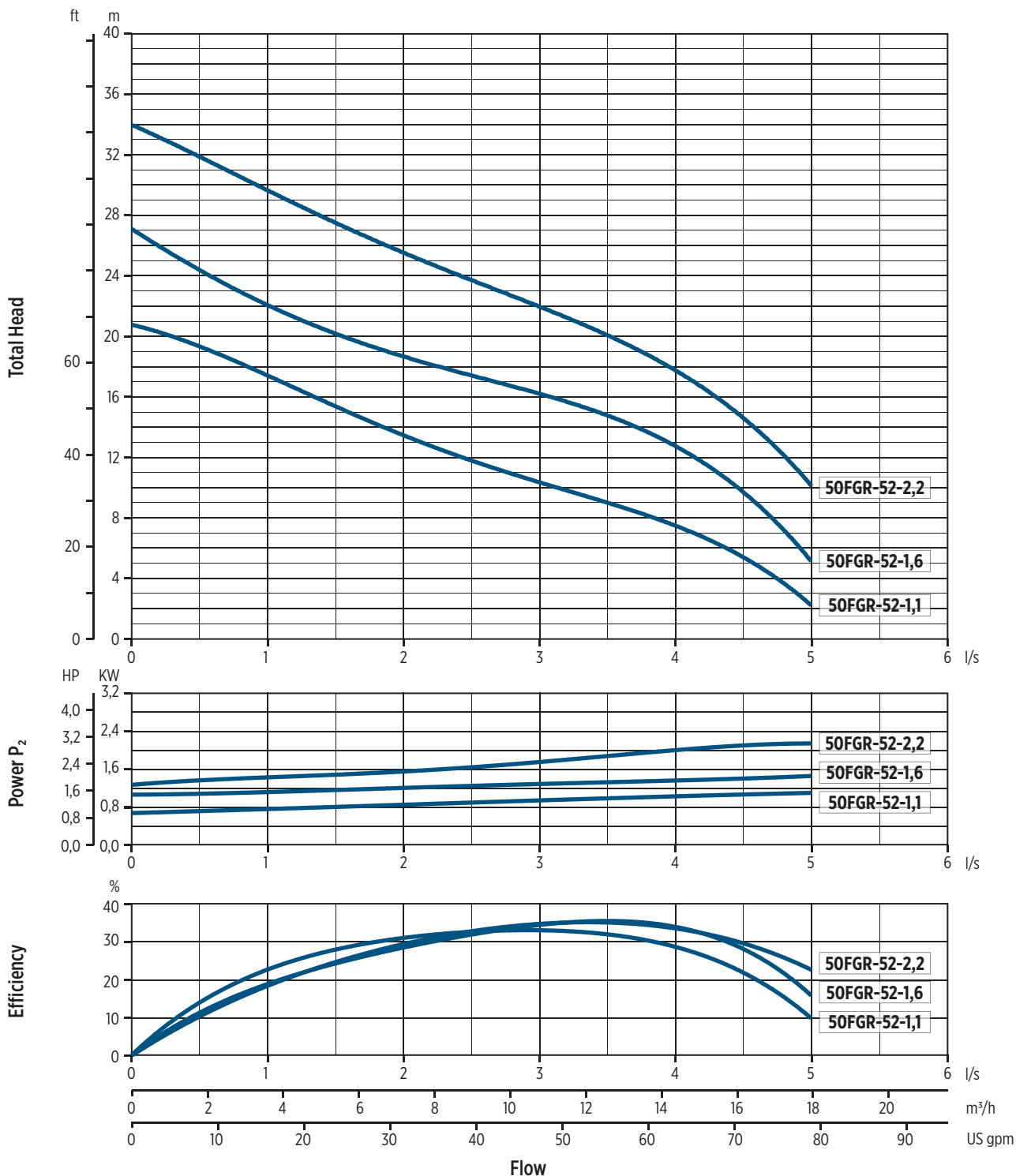

00201014_02/2023

INSTALLATION

INSTALLATION INSTRUCTIONS

PERMANENT INSTALLATION WITH COUPLING SYSTEM

It is the recommended installation for the permanent pumping station. The electric pump is guided by two pipes and it is connected automatically to the coupling system. The quick connection ensures that the pump can be easily removed and re-installed.

TRANSPORTABLE INSTALLATION

Transportable as emergency pump with connection to the hose and for free installation in the well.

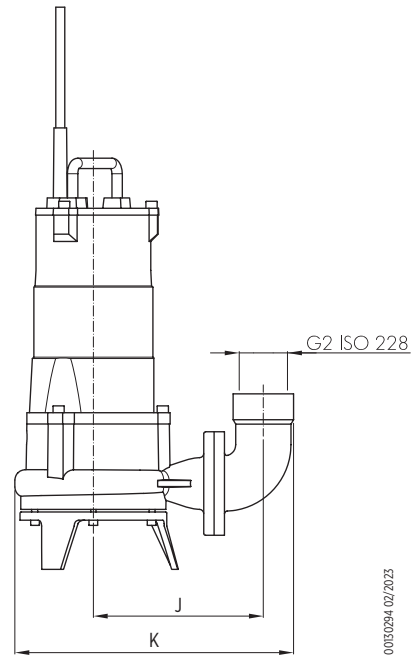
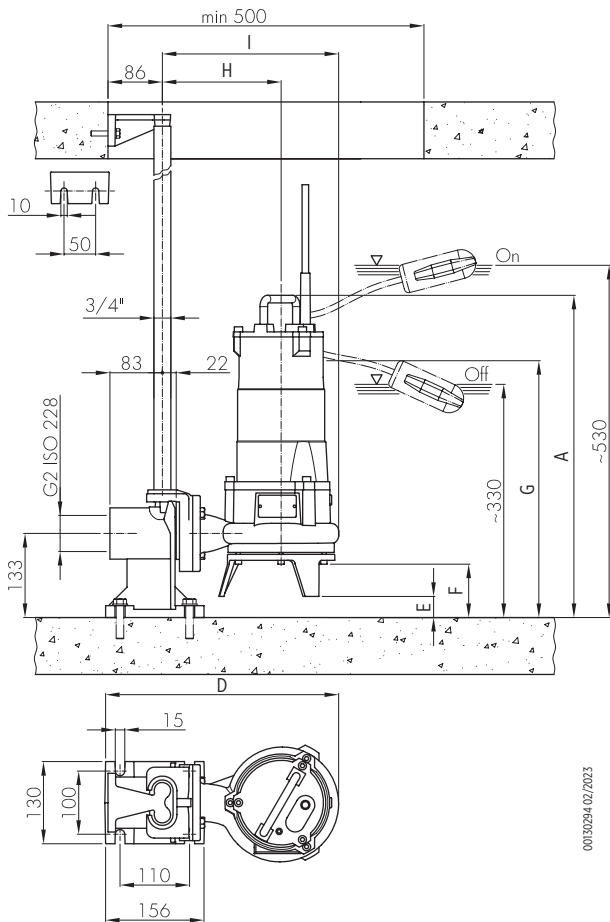

Pump model	Installation Dimensions [mm]								
	A	D	E	F	G	H	I	J	K
50FGR-52-1,1	510	370	34	85	407	193	279	197	232
50FGR-52-1,6	574	414	24	76	464	215	324	224	368
50FGR-52-2,2	574	414	24	76	464	215	324	224	368

FLV Series - D.C. motor submersible waste water lift pumps 50 Hz



D.C. MOTOR SUBMERSIBLE WASTE WATER LIFT PUMPS

PUMP IDENTIFICATION CODE

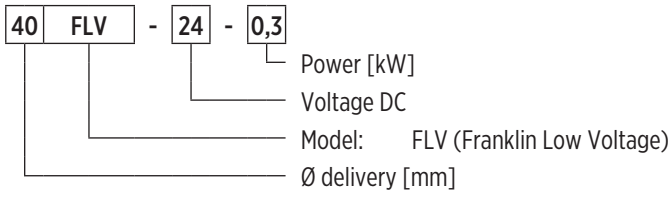

004008 01/2023

40FLV SERIES 50 HZ

FEATURES & BENEFITS

APPLICATIONS



Drainage



Domestic / industrial grey water



MARKETS



D.C. MOTOR SUBMERSIBLE WASTE WATER LIFT PUMPS

The D.C. electric submersible pumps are suitable for the drainage of water from road drain wells, basements and from sites where the electric current is not available. Easy to install and silent, this model offer the maximum safety.

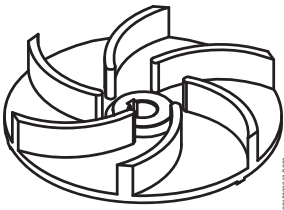

VORTEX IMPELLER

GENERAL FEATURES

Materials/Constr.design		
Vortex impeller		Cast iron EN GJL200
External casing		Stainless steel AISI304
Pump body		Cast iron EN GJL200
Cover		Cast iron EN GJL200
Mechanical seal	motor side 40FLV-24-0,3, 40FLV-24-0,5, 40FLV-24-0,75	Seal ring
	pump side 40FLV-24-0,3, 40FLV-24-0,5, 40FLV-24-0,75	Graphite/Alumina
	pump side 40FLV-12-0,3	Silicon carbide (SiC/SiC)
Motor shaft		Stainless steel AISI416
Power cable		5 m H07RN-F type, 2x6mm ²
Motor		
Constr.design		D.C. permanent magnet in dry chamber
Type		-
Insulation class		F
Protection degree		IP68
Main voltage values and relative tolerance in relation to the rated voltage value:		24V C.C. +10% / -5% 12V C.C. +10% / -5%
Limits of use		
Maximum liquid temperature		+40 °C
pH of pumped liquid		6 - 10
Liquid density		1,0 kg/dm ³
Maximum immersion depth:		2 m
Free passage		20 mm
Min. immersion depth for continuous service	40FLV-24-0,3, 40FLV-12-0,3,40FLV-24-0,5	300 mm
	40FLV-24-0,75	350 mm
Max. number of starting/hour		20
Construction options		

- Mechanical seal in Silicon carbide (SiC/SiC)
- Model 40FLV-12-0,3 with 10 m 1x16mm² cable and battery clamps
- Inlet with strainer (free passage 8 mm)

DIMENSIONAL DRAWINGS

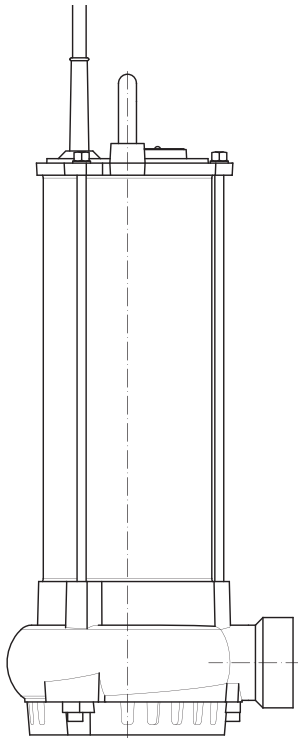

Version with filter on request

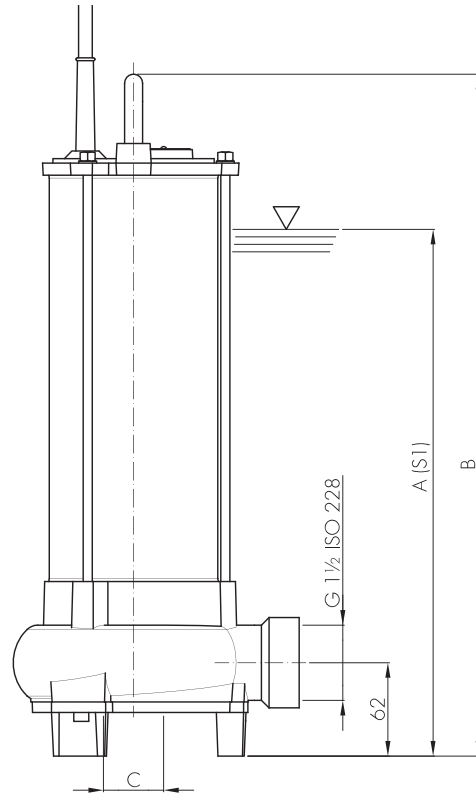

Dimensions [mm]			
Pump model	A	B	C
40FLV-24-0,3	300	402	30
40FLV-24-0,5	300	402	30
40FLV-24-0,75	350	453	40
40FLV-12-0,3	300	402	30

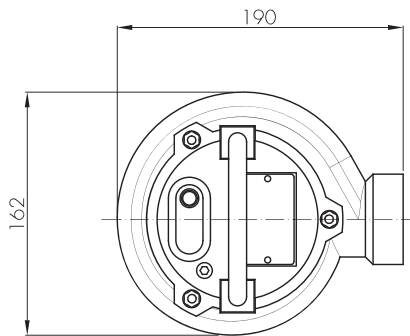

00130295 02/2023

Packaging		
Pump model	Dimensions [mm]	Weight [kg]
40FLV-24-0,3	220x180x450	11,5
40FLV-24-0,5	220x180x450	12,5
40FLV-24-0,75	220x200x450	17,7
40FLV-12-0,3	220x180x450	11,5

Pallet			
Pump model	Dimensions [mm]	N° of pumps	Weight [kg]
40FLV-24-0,3	800x1200x800	32	400
40FLV-24-0,5	800x1200x800	32	440
40FLV-24-0,75	800x1200x900	24	460
40FLV-12-0,3	800x1200x800	32	400

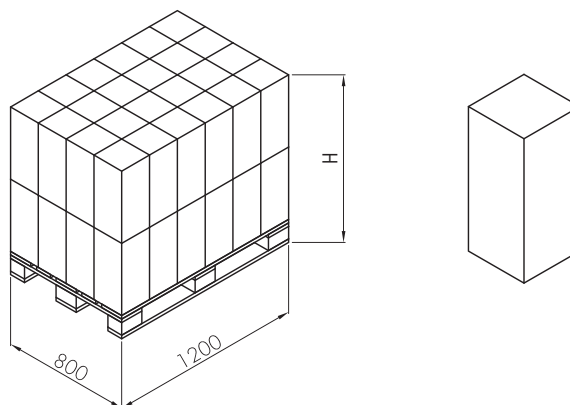

00130296 02/2023

TECHNICAL DATA

Pump model	Motor absorbed power P ₁	Rated power P ₂		Voltage	Rated current	Power cable		Delivery port	Weight [kg]
	[kW]	[kW]	[HP]	[V]	[A]	length [m]	Type		
40FLV-24-0,3	0,4	0,3	0,4	24DC	17	5	2X6	G1½	11
40FLV-24-0,5	0,62	0,5	0,7	24DC	26	5	2X6	G1½	12
40FLV-24-0,75	0,84	0,75	1	24DC	35	5	2X6	G1½	17
40FLV-12-0,3	0,4	0,3	0,4	12DC	34	5	2X6	G1½	11

“-” = not available

• = available

HYDRAULIC PERFORMANCE AT 50 HZ

Pump model	Voltage	Q = Delivery											
		l/sec 0	0,5	1	1,5	2	2,5	3	3,5	4	4,5	5	5,5
		m ³ /h 0	1,8	3,6	5,4	7,2	9	10,8	12,6	14,4	16,2	18	19,8
	US gpm 0	7,9	15,8	23,7	31,7	39,6	47,5	55,5	63,4	71,3	79,2	87,2	
[V]	H = Total meters head of water column [m]												
40FLV-24-0,3	24DC	8	7	6,2	5,3	4,3	3,2	2,1	1				
40FLV-24-0,5	24DC	10,9	9,7	8	7,1	6,8	6	5	3,9	2,9	1,5		
40FLV-24-0,75	24DC	12	11	10	9	8	7	5,8	5,1	4,5	3,9	3	2
40FLV-12-0,3	12DC	7,5	7	6	5	4	3,1	2,5	2	0,8			

PERFORMANCE CURVES AT 50 HZ

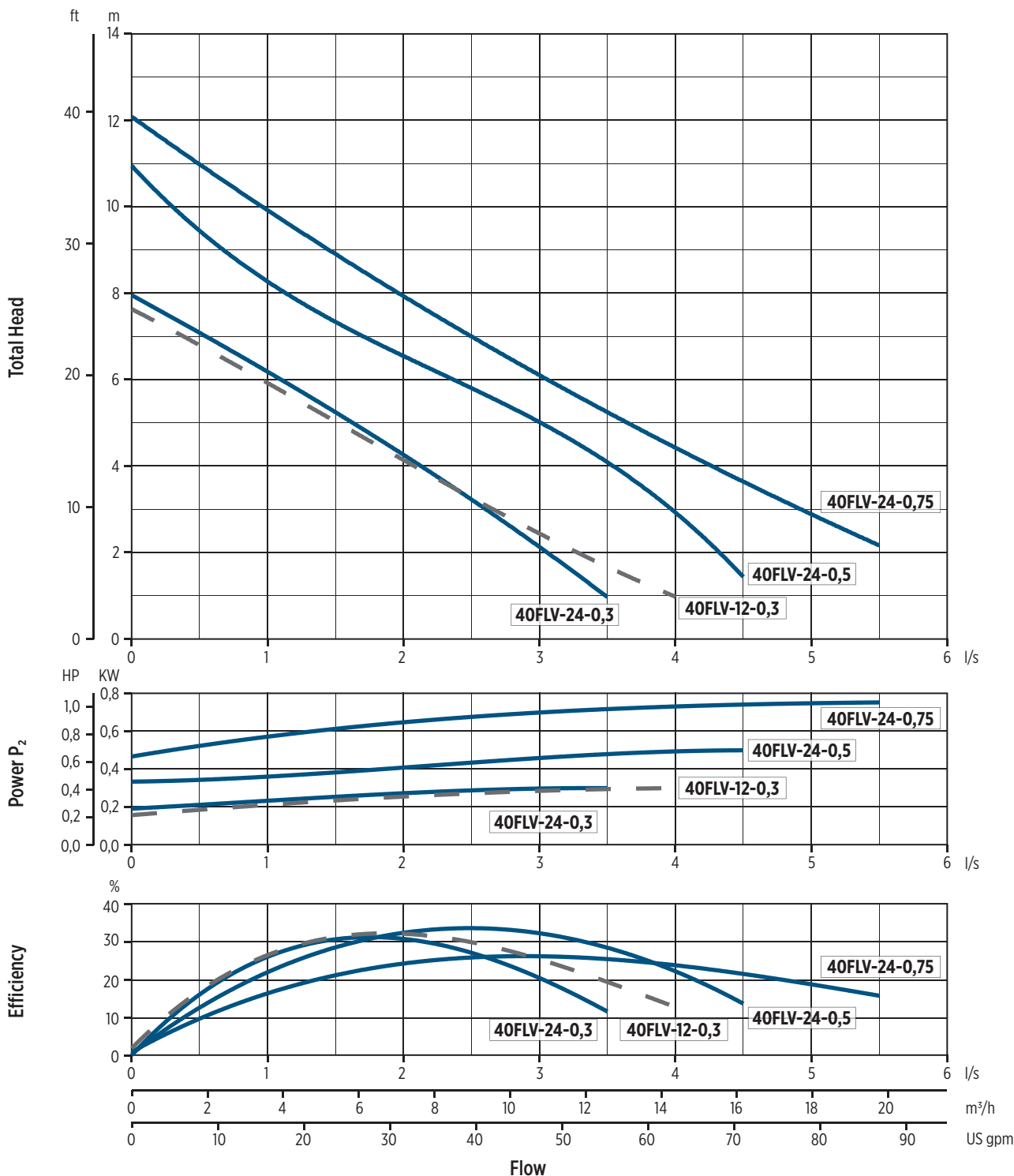

0020106 02/2023

INSTALLATION

INSTALLATION INSTRUCTIONS

TRANSPORTABLE INSTALLATION

Transportable as emergency pump with connection to the hose and for free installation in the well.

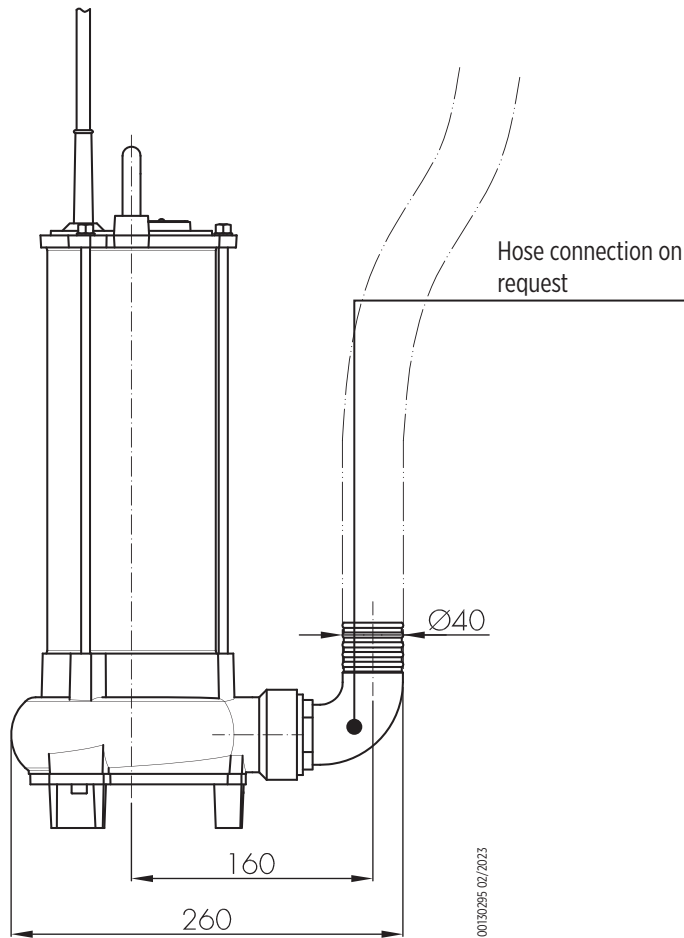

CATALOG REVISION CHANGE NOTICE

Rev. No.	Changes	Page
01	40FGR Technical data correction	84
02	Model correction: from "50FWC-V-54-1,5" to "50FWC-V-54-1,1"	38-42
03	Deleted sentence "Hose connection on request" from 50FWC and 50FGR	30, 36, 42, 92
03	40FGR General Features data table correction about power cable single-phase	82
03	50FGR General Features data table correction about power cable single-phase	88
03	50FWC-V-52-1,6M power cable sigle-phase correction to "4G2,5mm ² , capacitor box and SCHUKO plug (CEE 7/VII)"	38
03	50FWC V and 50FWC M Technical data correction from "0,75 HP" to "1,2 HP"	28, 34
03	50FGR (50FGR-52-1,1T, 50FGR-52-1,1T-G, 50FGR-52-1,6M, 50FGR-52-1,6M-G) Technical data correction: Motor absorbed Power P1 and Rated Power P2	90
03	50FGR Technical data correction - Running capacitor section	90
03	32FWS V, 40FWS V, 50FWS V General Features motor voltage single-phase correction	8, 14, 20



Geoquip Water Solutions Ltd. Unit
7, Sovereign Centre Farthing Road
Ipswich, Suffolk, IP1 5AP, UK Phone:
01473 462046
www.geoquipwatersolutions.com



Franklin Electric



franklinwater.eu

Franklin Electric Europa GmbH
Rudolf-Diesel-Str. 20 - 54516 Wittlich
GERMANY
Phone: +49 (0) 6571 - 105-0
Fax: +49 (0) 6571 - 105-510
Email: info@franklin-electric.de

Franklin Electric S.r.l.
Via Asolo, 7 - 36031 Dueville (Vicenza)
ITALY
Phone: +39 0444 361114
Fax: +39 0444 365247
Email: sales.it@fele.com



10000015088 EN REV.03_08-2023

Single member - Company subject to the control and coordination of Franklin Electric Co., Inc.
Franklin Electric reserves the right to amend specification without prior notice.